

**INSTRUCTION
MANUAL
FTV-700**

YAESU MUSEN CO., LTD.

C.P.O. BOX 1500
TOKYO, JAPAN

TABLE OF CONTENTS

	(Page)
GENERAL	1
SPECIFICATIONS	2
SEMICONDUCTORS	3
FRONT PANEL CONTROLS AND SWITCHES	4
REAR APRON	5
INSTALLATION	6
INTERCONNECTIONS	6
OPERATION	8
CRYSTAL DATA	11
CIRCUIT DESCRIPTION	12
MAINTENANCE & ALIGNMENT	21
PARTS LIST.....	28

YAESU FTV-700 VHF/UHF TRANSVERTER



GENERAL

The FTV-700 is a mono-band transverter for the FT-77 series. The basic unit comes equipped with complete control circuitry and any one of three bands (50 MHz, 144 MHz or 430 MHz) may be installed.

For satellite operators, three satellite bands are provided, allowing full duplex operation through the transceiver, using an external receiver in addition to the FTV-700. The operator may transmit on 145 MHz while listening on 29 MHz or 435 MHz, or transmit on 435 MHz while listening on 145 MHz.

The FTV-700 includes repeater splits on all repeater bands within its operating range. Fully solid state, the FTV-700 provides protection for the final amplifier transistors against damage caused by high SWR antenna connections.

The owner is urged to read this manual in its entirety, so as to become better acquainted with the exciting FTV-700. With proper care in operation, this equipment will provide many years of trouble-free operation.

SPECIFICATIONS

TRANSMITTER

Input frequency:
28 to 30 MHz

Input level:
0.22 volts (rms) max.

Input impedance:
50 ohms

DC Power input:
20 watts (SSB, CW)
5 watts (AM) (FM)

Transmit frequency range:
50 MHz to 54 MHz*
144 MHz to 148 MHz*
430 MHz to 440 MHz*

Output impedance:
50 ohms

Spurious radiation:
Better than 60 dB down

RECEIVER

Receiver frequency range:
50 MHz to 54 MHz*
144 MHz to 148 MHz*
430 MHz to 440 MHz*

Antenna input impedance:
50 ohms

Sensitivity:
0.25 μ V for S/N 10 dB (SSB, CW)**
0.7 μ V for SINAD 12 dB (FM)**

Output frequency range:
28 to 30 MHz

Output impedance:
50 ohms

GENERAL

Power requirement:
13.5V \pm 10% Negative ground

Current consumption:
3.5A

Size:
238 (W) x 55 (H) x 236 (D) mm

Weight:
2 kg.

* 50, 144, 430 MHz units optional
** When used with FT-77

SEMICONDUCTORS

MAIN CHASSIS	50MHz UNIT	144MHz UNIT	430MHz UNIT
FET:	FET:	FET:	Transistor:
3SK59Y 1	3SK51-03 3	3SK51-03 3	2SC784R 1
2SK19TM-GR 1			2SC1424 5
	Transistor:	Transistor:	2SC1426 1
Transistor:	2SC730 1	2SC730 1	2SC1815Y 2
2SA564Q 1	2SC784R 2	2SC784R 3	2SC2369 2
2SC1815Y 1	2SC1815Y 2	2SC1815Y 2	
2SC1815GR 2	2SC1945D 1	2SC2053 1	IC:
	2SC2053 1		78L08 1
IC:	2SC2166 1	IC:	
MC14066BP 3		MC1496G 1	Power module:
μPC14308 1	IC:	78L08 1	UP-07BL 1
	MC1496G 1		
Silicon diode:	78L08 1	Power module:	Germanium diode:
10D1 2		VP-20BL 1	1S188FM 4
1S1555 26	Germanium diode:		
	1S188FM 1	Germanium diode:	Silicon diode:
Varistor diode:		1S188FM 1	1S1555 2
MV103 1	Silicon diode:		MI301 3
	1S1555 12	Silicon diode:	1SS53 10
Zener diode:	1SS53 4	1S1555 3	10D1 1
WZ081 1	10D1 3	1SS53 11	
WZ110 1		10D1 1	Schottky barrier diode:
	Varactor diode:		1SS97 4
LED:	1S2209 8	Varactor diode:	
TLY205 1		1S2209 4	

Specifications subject to change without notice.

ACCESSORIES

The following accessories are included with your FTV-700:

Cable "A"	(T9100071A)	1 pc.
Cable "B"	(T9100160A)	1 pc.
Speaker cord	(T9101272)	1 pc.
Screw	(U00310001)	2 pcs.
Spacer	(R6052652)	1 pc.
Spare Fuse 5A	(Q0000005)	1 pc.

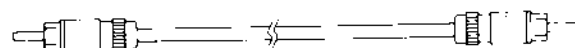

CABLE A

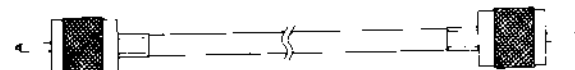

CABLE B

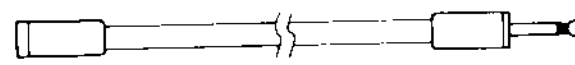

SPEAKER CORD



SCREW FOR CONVERTER UNIT FIX



SPACER
Use for 430MHz UNIT



FUSE

FRONT PANEL CONTROLS AND SWITCHES

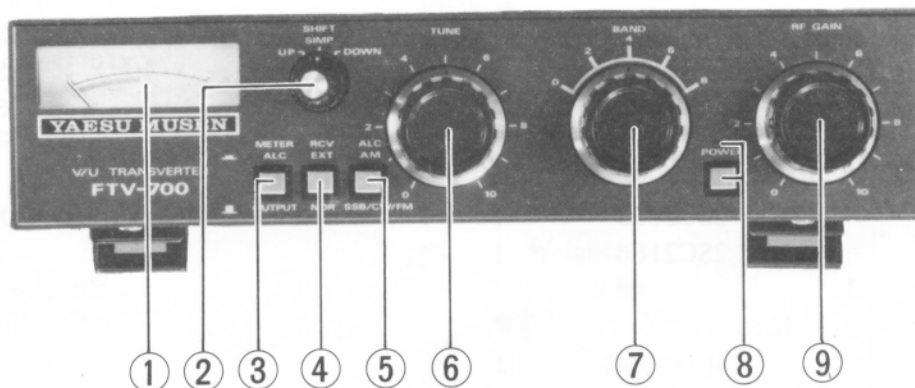

(1) Meter

Depending on the position of the METER switch, the front panel meter will display either the ALC or relative output power level.

(2) SHIFT

This switch selects UP/DOWN repeater shift or simplex operation.

(3) METER (Switch)

This switch selects indication of either the relative output power or the ALC level on the front panel meter.

(4) RCV

This switch allows selection of the receive operation using the FT-77 transceiver (NOR) or an external receiver (EXT) for satellite work, etc.

(5) ALC

This switch selects ALC for SSB/CW/FM, or AM. Select this switch according to your operation mode (AM position not used with FT-77).

(6) TUNE

For 50 or 144 MHz operation, this control peaks the transmit and receive circuits for maximum performance. On 430 MHz, the tuned circuits of the transverter are preset, and no tuning is required.

(7) BAND

For 50 or 144 MHz operation, two bands are provided. These bands allow a coverage of 4 MHz, in conjunction with the four 500 kHz ranges of the FT-77 10 meter band. For 430 MHz operation, 5 bands are provided, allowing operation on the 10 MHz range of 430 – 440 MHz.

(8) POWER

This is the main power ON/OFF switch. When the switch is set to OFF, the FTV-700 is bypassed and the HF antenna is connected to the transceiver.

(9) RF GAIN

For 50 or 144 MHz operation, this control varies the gain of the RF amplifier stage.

On 430 MHz, this control has no effect as the RF amplifier is always set for maximum gain.

REAR APRON

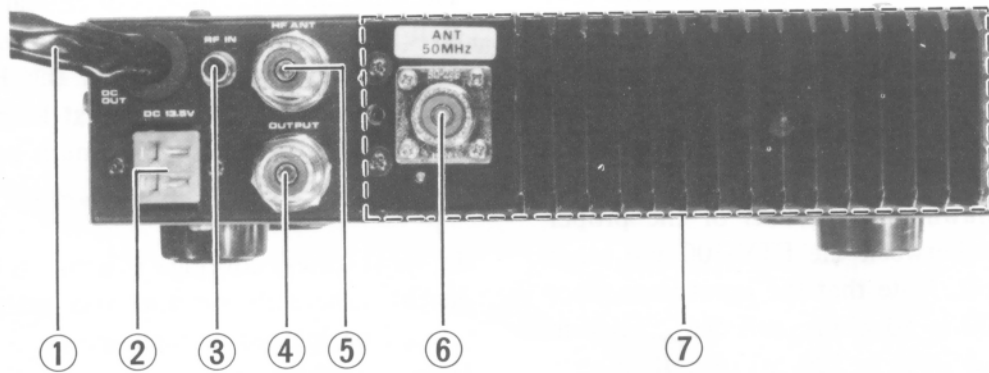

(1) DC OUT

This lead provides DC voltage to the FT-77 transceiver. When the FTV-700 is switched off, the DC voltage is automatically fed to the final stage of the FT-77.

(2) DC 13.5V

This is the power jack of the FTV-700. Connect the plug of the FP-700 DC power supply at this point.

(3) RF IN

This RCA jack is for connection to the FT-77 RF OUT jack. Use the supplied "Cable A" for this connection.

(4) OUTPUT

This jack should be connected to the FT-77 ANT jack, providing converted receive signals to the transceiver. When the FTV-700 is off, the HF ANT is connected through this jack to the FT-77. For this connection, use the supplied "Cable B".

(5) HF ANT

Connect the HF antenna or HF antenna tuner to this jack. When using a linear amplifier for the HF bands, connect a coaxial cable between this jack and the amplifier RF input jack. The switching circuit is not designed to handle the high power output from an amplifier.

(6) ANT JACK

Connect the VHF or UHF antenna, matched to operating band, to this jack. For 144 and 50 MHz units, a PL-259 plug is suitable for this jack. For 430 MHz units, a "Type N" plug must be used.

(7) 50/144/430 UNIT (Option)

This rack is for installation of the 50, 144 or 430 MHz unit, depending on your desired band.

INSTALLATION

Open the packing carton carefully and save the packing material for possible use at a later date. Inspect the FTV-700 for any signs of damage that may have occurred during shipment. If there is any visible damage, contact the shipping company immediately, and document the damage thoroughly.

Refer to the drawings for details of the proper interconnections between the FTV-700 and other station equipment. Note that the input impedance for the FTV-700 is 50 ohms, and the maximum permissible input level is 220 mVrms. If using a transceiver other than the FT-77, be certain not to exceed these specifications.

The transverter may be installed in any position without loss of performance. The only constraint regarding installation is that it must be located where there is free passage of air around the cabinet and heat sink.

ANTENNA CONSIDERATIONS

The antenna installation is of critical importance in VHF and UHF bands. The power loss in the coaxial cable is higher than that on the HF bands. To minimize loss, use the shortest length possible of low-loss cable, so that maximum performance of the FTV-700 will be obtained.

In most cases, coverage is a function of antenna height. The antenna for base station operation should be located as high and in the clear as possible. For long distance communication, a gain antenna such as a Yagi or other directional array is most effective. Your nearest Yaesu dealer will be happy to recommend the most suitable antenna for your requirements.

INTERCONNECTIONS

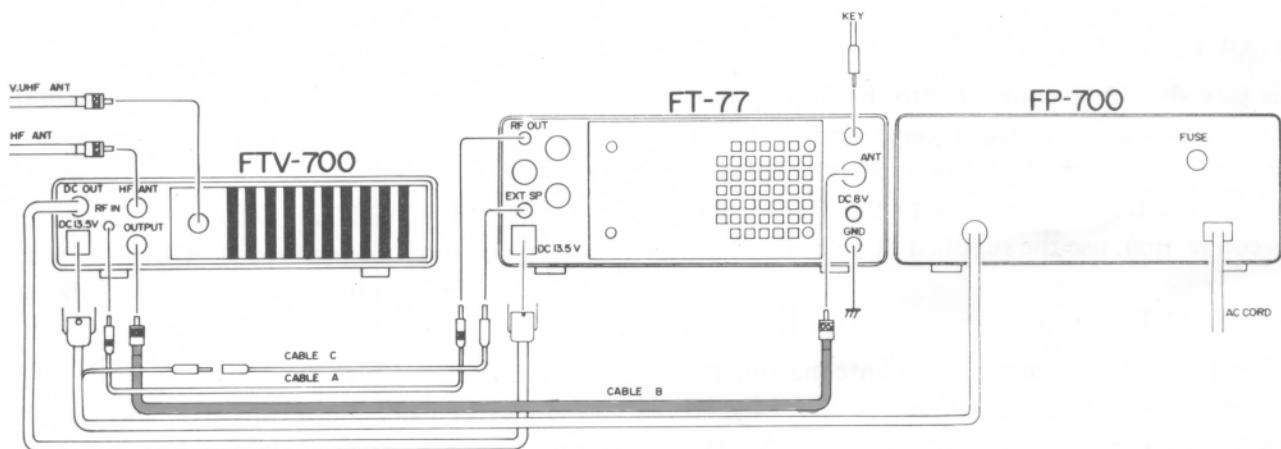

INSTALLATION OF OPTIONAL MODULES

1. Remove the top cover of the transverter to allow precise installation.
2. Carefully slide the module into the correct position. Do not force the connection. For the 430 MHz unit, install a spacer into the screw at the rear of the 430 MHz unit, as shown below, and then install the unit into the rack.
3. Replace the cabinet cover. Installation is now complete.

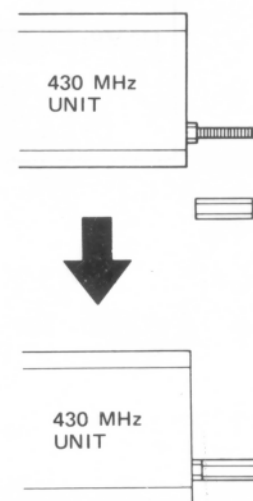
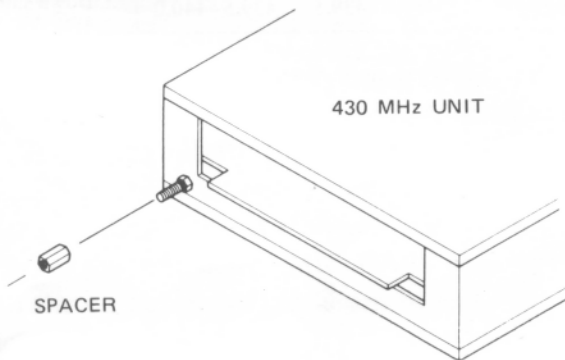
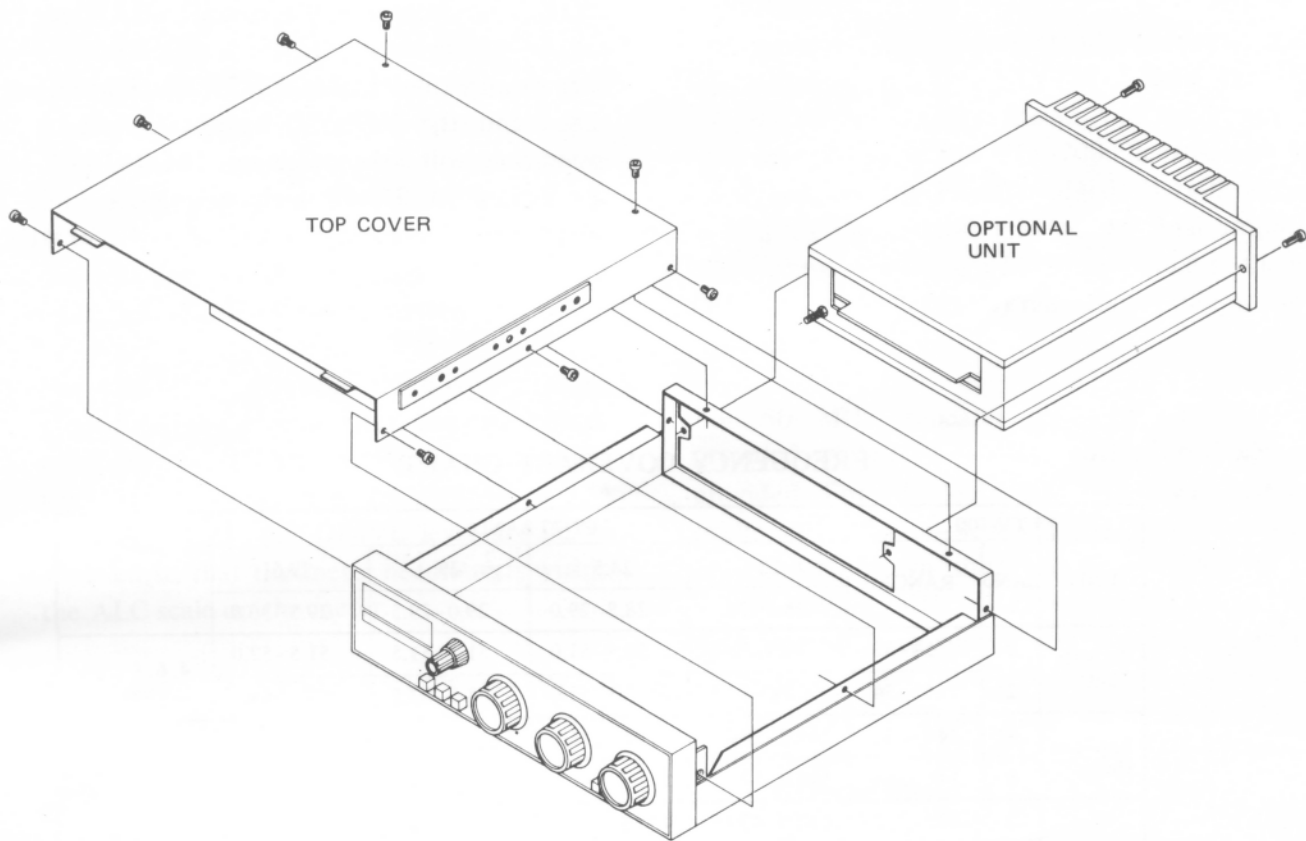

OPERATION

The tuning procedure for the FTV-700 is not complicated. However, care should be observed so as not to exceed the ratings of the transverter and the HF transceiver. It is assumed that the proper interconnections have been made, as shown on page 7.

Note that the plug-in units are optional on the standard FTV-700. The word "option" will hereafter be omitted in the interest of brevity.

INITIAL CHECK

Before turning the FTV-700 and FT-77 on, check all other switches and controls on the transverter for normal, smooth action. Recheck the interconnections between the HF equipment, the antenna system, and the transverter.

FREQUENCY SELECTION

The operating frequency is determined by the position of the main tuning dial and bandswitch of the transceiver, as well as the position of the transverter bandswitch. Refer to the frequency chart below.

For example; with the FT-77 bandswitch set to 28, and the FTV-700 bandswitch set to "4", operation will take place on 144.0-144.5 MHz. By setting the FT-77 main tuning dial to 28.250 MHz, operation will take place on 144.250 MHz.

FREQUENCY COVERAGE CHART

FTV-700			FT-77 BAND				
UNIT	BAND	RANGE	28	28.5	29	29.5	
			28.0-28.5	28.5-29.0	29.0-29.5	29.5-30.0	
50 MHz Unit	0	50-52	50.0-50.5	50.5-51.0	51.0-51.5	51.5-52.0	4, 6, 8 not used
	2	52-54	52.0-52.5	52.5-53.0	53.0-53.5	53.5-54.0	
144 MHz Unit	4	144-146	144.0-144.5	144.5-145.0	145.0-145.5	145.5-146.0	0, 2, 8 not used
	6	146-148	146.0-146.5	146.5-147.0	147.0-147.5	147.5-148.0	
430 MHz Unit	0	430-432	430.0-430.5	430.5-431.0	431.0-431.5	431.5-432.0	Shift operation not possible
	2	432-434	432.0-432.5	432.5-433.0	433.0-433.5	433.5-434.0	
	4	434-436	434.0-434.5	434.5-435.0	435.0-435.5	435.5-436.0	
	6	436-438	436.0-436.5	436.5-437.0	437.0-437.5	437.5-438.0	
	8	438-440	438.0-438.5	438.5-439.0	439.0-439.5	439.5-440.0	... Down shift available

NORMAL TUNE UP

- (1) Set the FTV-700 SHIFT switch to SIMP, the RCV switch to NOR, the METER switch to ALC, the ALC switch to SSB/CW, and the BAND switch to the desired band. Set up the transceiver for operation on the section of the 10 meter band corresponding to the VHF or UHF frequency to be worked (Chart, page 8).
- (2) Set the FTV-700 POWER switch to ON.
- (3) Set the transceiver DRIVE control fully counter-clockwise, and close the PTT switch. For 50 or 144 MHz operation, apply a key-down signal, and advance the transceiver DRIVE control until the ALC meter needle on the FTV-700 reaches the right-hand edge of the ALC scale so that the needle points straight up (the ALC scale is the lowermost range on the meter). Now set the FTV-700 METER switch to OUTPUT, and rotate the TUNE control for maximum power output as indicated on the transverter meter.
- (4) For 430 MHz operation, there is no peaking procedure for the transverter. The only adjustment that must be made is to set the input level to the transverter. As with 50 or 144 MHz operation, the DRIVE level should be adjusted so that the meter needle rests within the ALC scale on the meter.
- (5) For FM and CW operation, set the ALC switch to SSB/CW/FM. Do not advance the DRIVE control of the transceiver so that the ALC meter needle goes beyond the ALC scale on the meter.
- (6) For SSB operation, adjust the transceiver MIC GAIN so that the meter needle stays within the ALC meter scale on voice peaks.
- (7) For AM operation (with transceivers so equipped) set the ALC switch to AM. Set the METER switch to OUTPUT, and advance the transceiver DRIVE control until the meter needle reaches .3 on the output scale. Now advance the transceiver MIC GAIN control until the output meter just begins to move on voice peaks.
- (8) Advancing the drive level beyond that stated above will not increase the power output. However, component life may be shortened drastically if these maximum input levels are exceeded.
- (9) For 50 or 144 MHz operation, rotating the FTV-700 RF GAIN control will provide adjustment of the receive converter gain level. For 430 MHz operation, this control has no effect, as the converter is always set for maximum gain.

REPEATER OPERATION

For operation on repeaters, standard repeater shifts are provided on the FTV-700. Note that the FT-902DM/101ZD/102 transceivers may not be used directly with the FTV-700, because the RF OUT jack on the FT-902DM/101ZD/102 is connected to the control grid of the final amplifier tubes, thus presenting a high impedance at the RF OUT jack. The FTV-700 requires a 50-ohm input from the transceiver.

For 50 MHz, repeater splits of -1 MHz are provided, while on 144 MHz, splits of ± 600 kHz are provided. For 430 MHz, 1.6 MHz down shift will occur on the 434.6–434.825 MHz European band, or 7.6 MHz down shift can be provided on the 438.6–439.05 MHz European band (note that only one shift capability can be installed in the FTV-700). The 70 cm repeater shift crystal is an option, available from your Yaesu dealer. The 6 and 2 meter crystals are included with all plug-in units for those bands.

SATELLITE OPERATION

Operation on the amateur satellites is possible, using an external receiver in addition to the FT-77 transceiver. The FT-77 provides the transmit signal, while the external receiver monitors the downlink, on full duplex.

For OSCAR Mode A, transmission takes place on 145.850–145.950 MHz, with reception on 29.400–29.500 MHz. Set the FTV-700 BAND switch to the 4 position, and set the FT-77 BAND switch to 29.5. Tune the transceiver between 29.850 and 28.950 MHz for uplink transmission via the FTV-700, and tune the external receiver to 29.4–29.5 MHz for downlink monitoring.

Note that, because of Doppler effect and other reasons, the frequency translation may not be precisely linear. Some precise zeroing using the external receiver may be necessary.

AUXILIARY REPEATER SPLIT INFORMATION

Should you require a repeater split other than the standard ones included with your FTV-700, you may install an optional crystal to cover the desired split. See your Yaesu dealer for details.

To align the split frequency, set the RPT split to DWN, and couple a frequency counter lightly to the transmission line (a one-turn loop is usually sufficient). Close the PTT switch, and adjust the trimmer capacitor for the crystal for exactly the correct transmit frequency. Alternatively, the frequency counter may be connected to the LOCAL OUT terminal of the board under test, and the local oscillator frequency may then be read on the counter. The local oscillator chart on page 11 shows how to calculate the frequency.

CRYSTAL DATA:FTV-700

FUNCTION		HOLDER	RANGE (MHz)	MODE	LOAD C	EFFECTIVE RESISTANCE	DRIVE LEVEL
50 MHz	X ₂₀₁	HC-18/U	22.0	Fundamental	19 pF	15 Ω	2 mW
	X ₂₀₂	"	24.0	"	"	"	"
	X ₂₀₅	HC-25/U	21.0	"	"	"	"
	X ₂₀₆	"	23.0	"	"	"	"
144 MHz	X ₆₀₁	HC-18/U	38.666..	3rd overtone	15 pF	25 Ω	"
	X ₆₀₂	"	39.333..	"	"	"	"
	X ₆₀₃	HC-25/U	38.866..	"	"	"	"
	X ₆₀₄	"	39.533..	"	"	"	"
	X ₆₀₅	"	38.466..	"	"	"	"
	X ₆₀₆	"	39.133..	"	"	"	"
430 MHz	X ₁₆₀₁	HC-25/U	67.000	"	23.5 pF	40 Ω	0.5 mW
	X ₁₆₀₂	"	67.333..	"	"	"	"
	X ₁₆₀₃	"	67.666..	"	"	"	"
	X ₁₆₀₄	"	68.000	"	"	"	"
	X ₁₆₀₅	"	68.333..	"	"	"	"
	X ₁₆₀₆ (1.6MHz DOWN)	"	67.400	"	"	"	"
	X ₁₆₀₆ (7.6MHz DOWN)	"	67.066..	"	"	"	"

BAND	50MHz			
RANGE	50-52	52-54	50-52 (1MHz DOWN)	52-54 (1MHz DOWN)
LOCAL FREQUENCY	22MHz (x1)	24MHz (x1)	21MHz (x1)	23MHz (x1)
OSC. FREQUENCY	22MHz ☆	24MHz ☆	21MHz ☆	23MHz ☆

BAND	144MHz					
RANGE	144-146	146-148	144-146 (600kHz UP)	144-146 (600kHz DOWN)	146-148 (600kHz UP)	146-148 (600kHz DOWN)
LOCAL FREQUENCY	116MHz (x3)	118MHz (x3)	116.6MHz (x3)	115.4MHz (x3)	118.6MHz (x3)	117.4MHz (x3)
OSC. FREQUENCY	38.666...MHz ▲	39.333...MHz ▲	38.866...MHz ▲	38.466...MHz ▲	39.533...MHz ▲	39.133...MHz ▲

BAND	430MHz						
RANGE	430-432	432-434	434-436	436-438	438-440	434-436 (1.6MHz DOWN)	438-440 (7.6MHz DOWN)
LOCAL FREQUENCY	402MHz (x3x2)	404MHz (x3x2)	406MHz (x3x2)	408MHz (x3x2)	410MHz (x3x2)	404.4MHz (x3x2)	402.4MHz (x3x2)
OSC. FREQUENCY	67.000MHz ▲	67.333...MHz▲	67.666...MHz▲	68.000MHz ▲	68.333...MHz▲	67.400MHz ▲	67.066...MHz▲

☆ FUNDAMENTAL
▲ THIRD OVERTONE

CIRCUIT DESCRIPTION

The circuit description to follow should help you understand the operation of the FTV-700 transmitter. Follow the block diagrams while reading this discussion, and refer to the schematic diagrams for specific details.

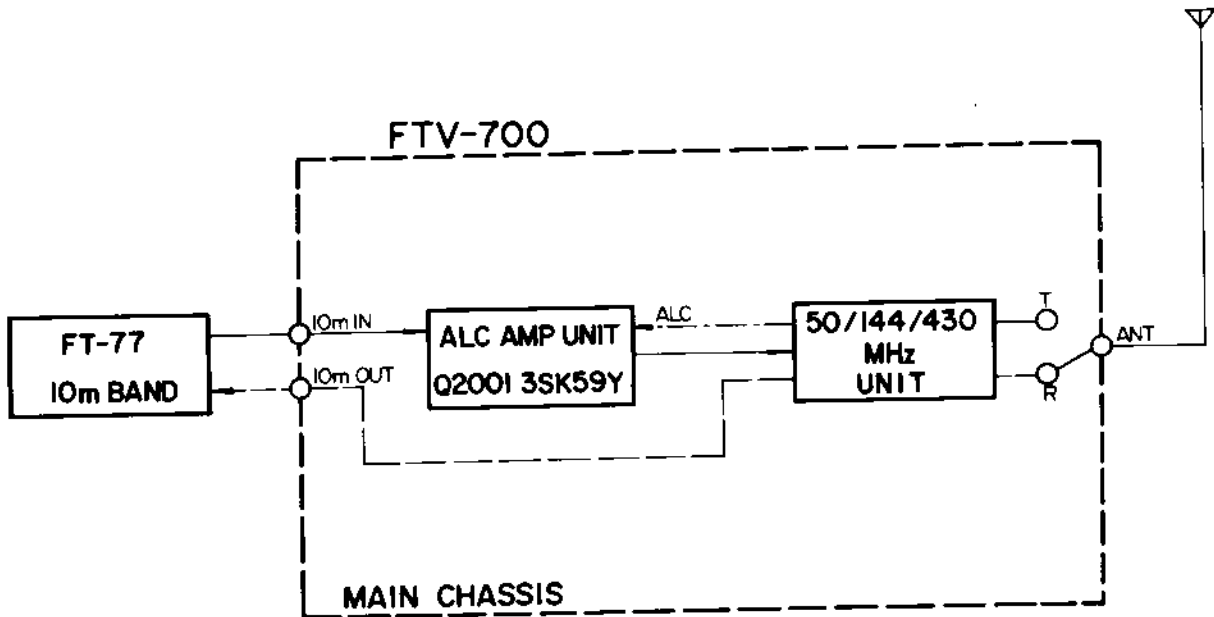

FTV-700 BLOCK DIAGRAM

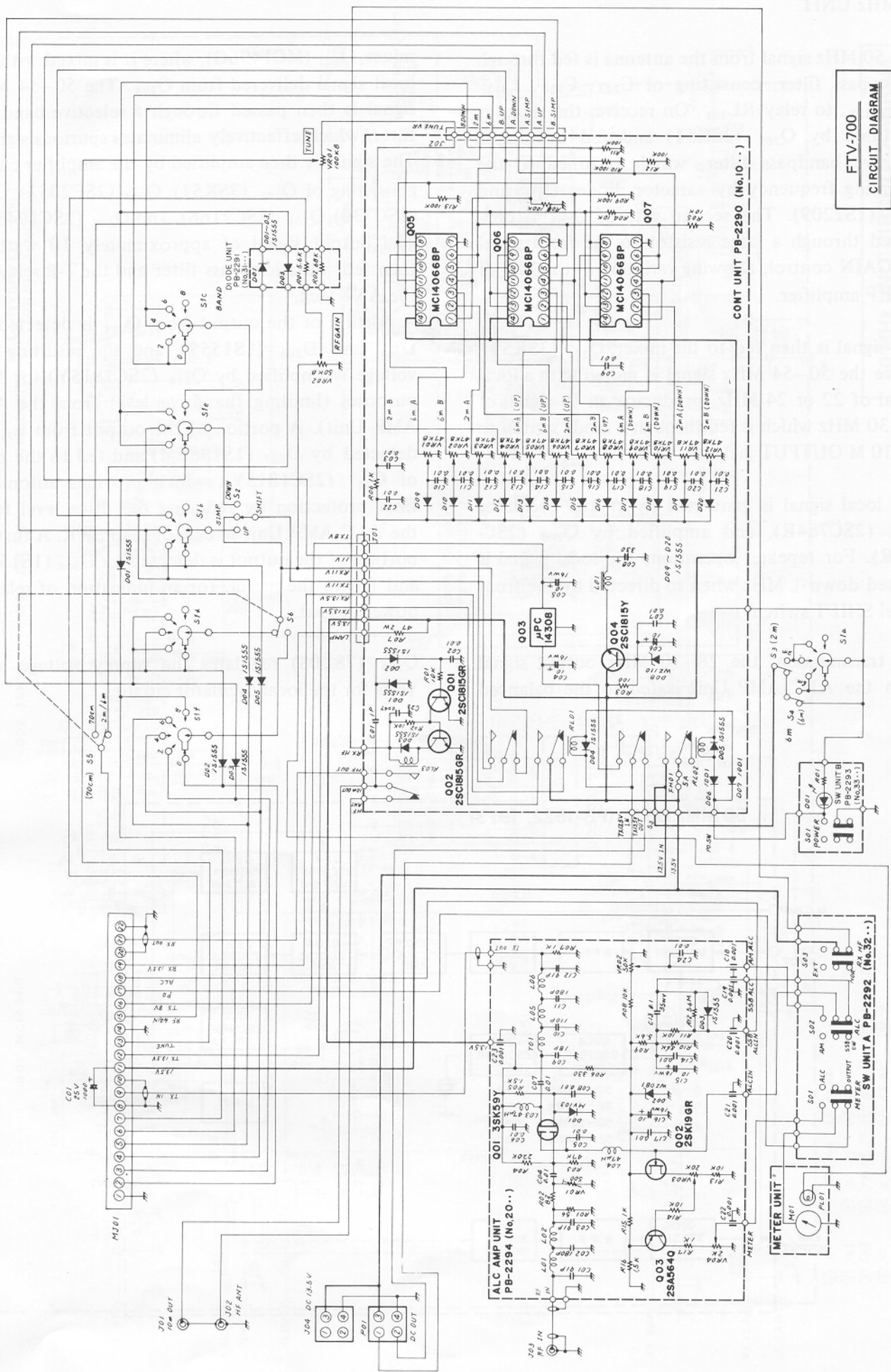

FTV-700
CIRCUIT DIAGRAM

50 MHz UNIT

The 50 MHz signal from the antenna is fed through a low-pass filter, consisting of C_{323} , C_{324} , L_{312} and L_{313} , to relay RL_{301} . On receive, the signal is amplified by Q_{205} (3SK51) and fed through a selective bandpass filter, which is tuned to the operating frequency by varactor diodes D_{210} and D_{211} (1S2209). The second gate of Q_{205} is connected through a large resistor to the front panel RF GAIN control, allowing variation in the gain of the RF amplifier.

The signal is then fed to the mixer, Q_{206} (3SK51), where the 50–54 MHz signal is mixed with a local signal of 22 or 24 MHz, producing an IF signal of 28–30 MHz which is fed through a diode switch to the 10 M OUTPUT jack.

The local signal is generated by crystal oscillator Q_{207} (2SC784R), and amplified by Q_{208} (2SC784R). For repeater operation, the local signal is shifted down 1 MHz when so directed by the front panel SHIFT switch.

For transmission, the 28–30 MHz output signal from the ALC AMP Unit is fed to the balanced

mixer, Q_{201} (MC1496G), where it is mixed with the local signal delivered from Q_{208} . The 50–54 MHz signal is then passed through a selective bandpass filter, which effectively eliminates spurious signals. The signal is then amplified by the amplifier chain, consisting of Q_{202} (3SK51), Q_{203} (2SC2053), Q_{204} (2SC730), Q_{301} (2SC2166), and Q_{302} (2SC1945D). The output signal of approximately 10 watts is then fed, via a low pass filter and the T-R relay, to the ANT jack.

A portion of the output from Q_{301} is detected by D_{303} and D_{304} (1S1555), and the resulting DC voltage is amplified by Q_{210} (2SC1815Y) for ALC purposes (limiting the drive level from the ALC AMP Unit). A portion of the output from L_{311} is detected by D_{307} (1S188FM) and fed to the base of Q_{211} (2SC1815Y), which provides automatic final protection by reducing the drive level from the ALC AMP Unit in case of high SWR. A further portion of the output is detected by D_{305} (1S1555) and fed to the meter, for an indication of relative power output.

Q_{209} (78L08) regulates the supply voltage at 8 volts for the local oscillator circuit.

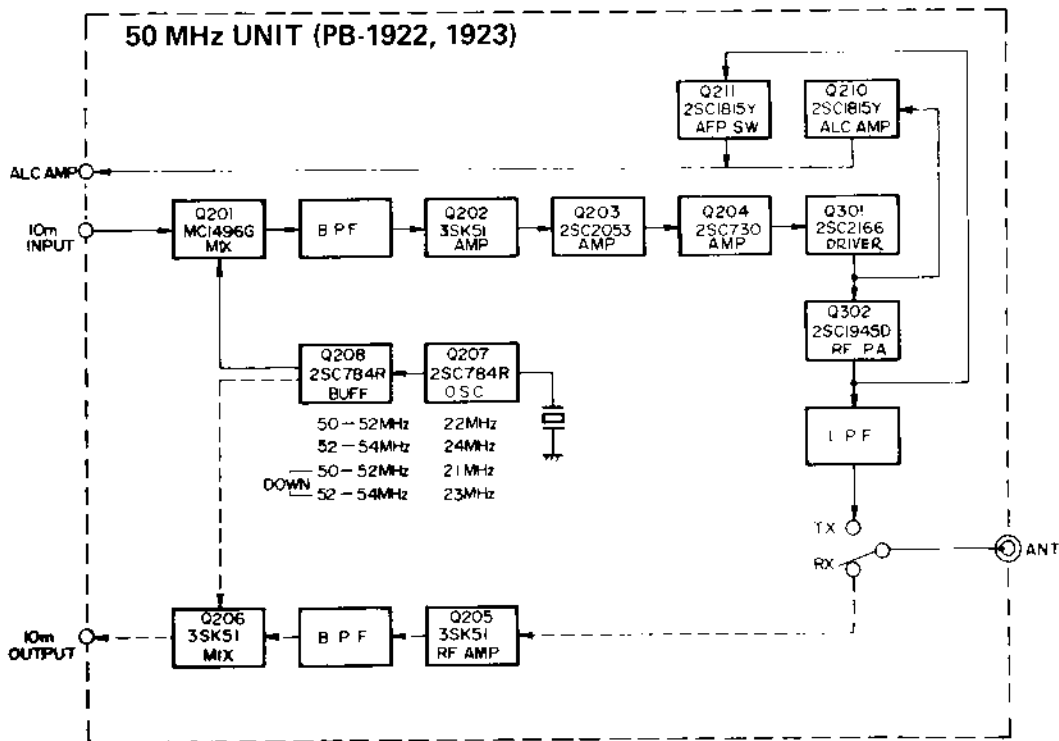

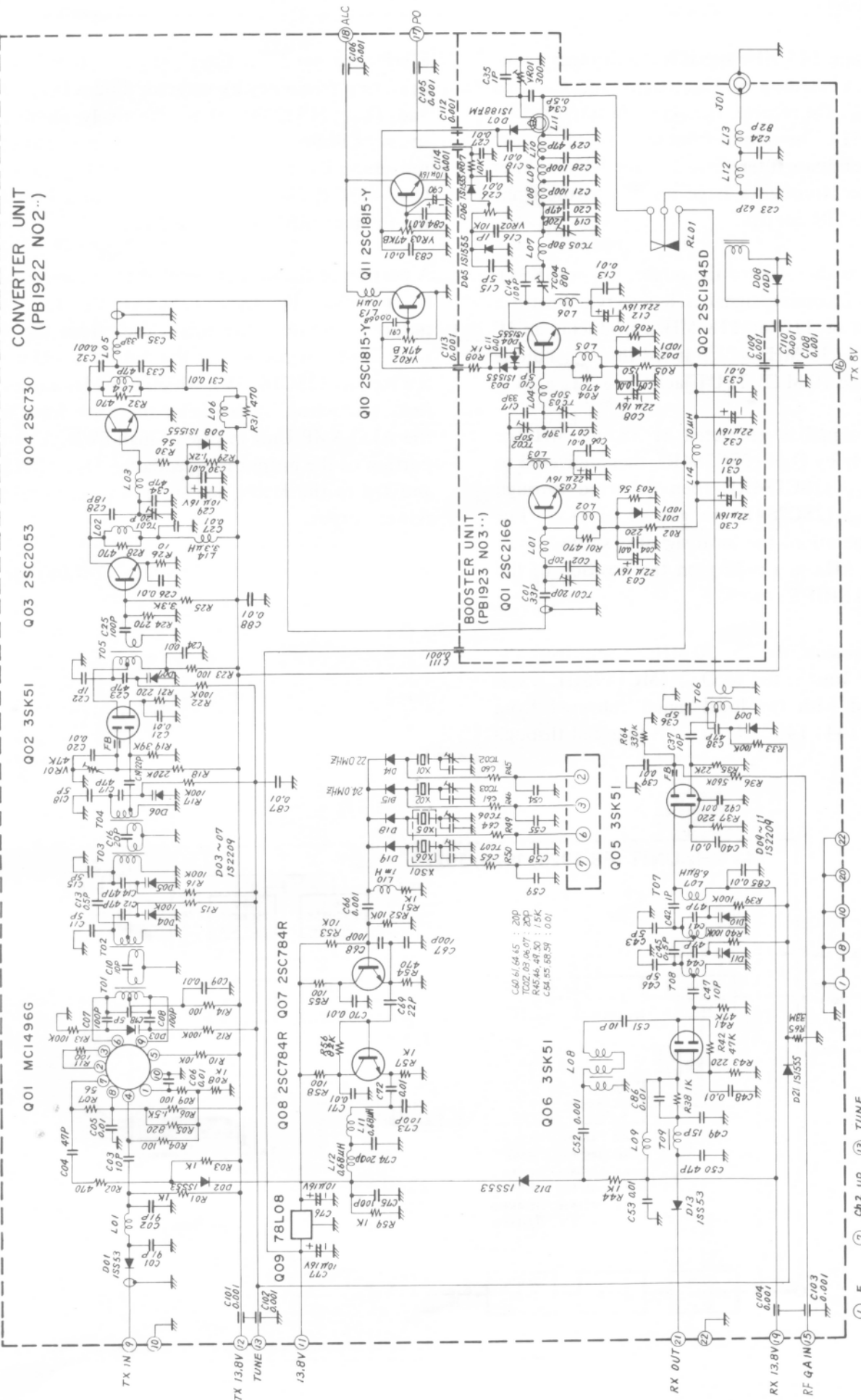

50 MHz UNIT CIRCUIT DIAGRAM

- ① E
- ② CH1
- ③ CH2
- ④ NC
- ⑤ NC
- ⑥ CH1 up
- ⑦ CH2 up
- ⑧ E
- ⑨ TX IN
- ⑩ NC
- ⑪ 13.8V
- ⑫ TX 13.8V
- ⑬ TUNE
- ⑭ NC
- ⑮ GAIN
- ⑯ RX 13.8V
- ⑰ TX 8V
- ⑱ E
- ⑲ RX OUT
- ⑳ P0
- ㉑ 13.8V
- ㉒ TX 13.8V
- ㉓ ALC

144 MHz UNIT

The incoming 144 MHz signal is fed through a low-pass filter, consisting of L_{708} , C_{716} , and C_{717} , to relay RL_{701} . On receive, the signal is amplified by Q_{605} (3SK51). The output from Q_{605} is fed through a 4-stage bandpass filter. Gate 2 of the RF amplifier is connected through a large resistor to the front panel RF GAIN control.

The signal is then fed to the mixer, Q_{606} (3SK51), where the incoming signal is heterodyned with a local signal of 116 or 118 MHz, producing an IF signal of 28–30 MHz which is fed through a diode switch to the 10 M OUTPUT jack.

The local signal is generated at 38.666 MHz or 39.333 MHz by Q_{607} (2SC784R), then delivered to tripler Q_{608} (2SC784R), then delivered through buffer Q_{609} (2SC784R) to gate 2 of Q_{606} . For repeater operation, the local signal is shifted up or down 600 kHz, depending on the position of the front panel SHIFT switch.

For transmission, the 28–30 MHz output from the ALC AMP Unit is fed to Q_{601} (MC1496G), where it is mixed with the local signal delivered from Q_{609} . The 144–148 MHz signal is then fed through

a selective bandpass filter, which is tuned to the operating frequency by varactor diodes D_{602} , D_{603} , and D_{604} (1S2209), thus effectively eliminating spurious responses. The signal is then amplified by the amplifier chain, consisting of Q_{602} (3SK51), Q_{603} (2SC2053), Q_{604} (2SC730), and delivered to the final amplifier, Q_{701} (VP-20BL).

A portion of the output signal at the power module is amplified by Q_{612} (2SC1815Y) for ALC purposes (limiting the drive level from the ALC AMP Unit). A portion of the output signal is also fed to Q_{611} (2SC1815Y), which provides automatic final protection by reducing the drive level from the ALC AMP Unit in case of high SWR. A further portion of the output is detected by D_{702} (1S1555) and fed to the meter, for an indication of relative power output.

The 8 volt line is regulated by Q_{610} (78L08) for the local oscillator circuitry.

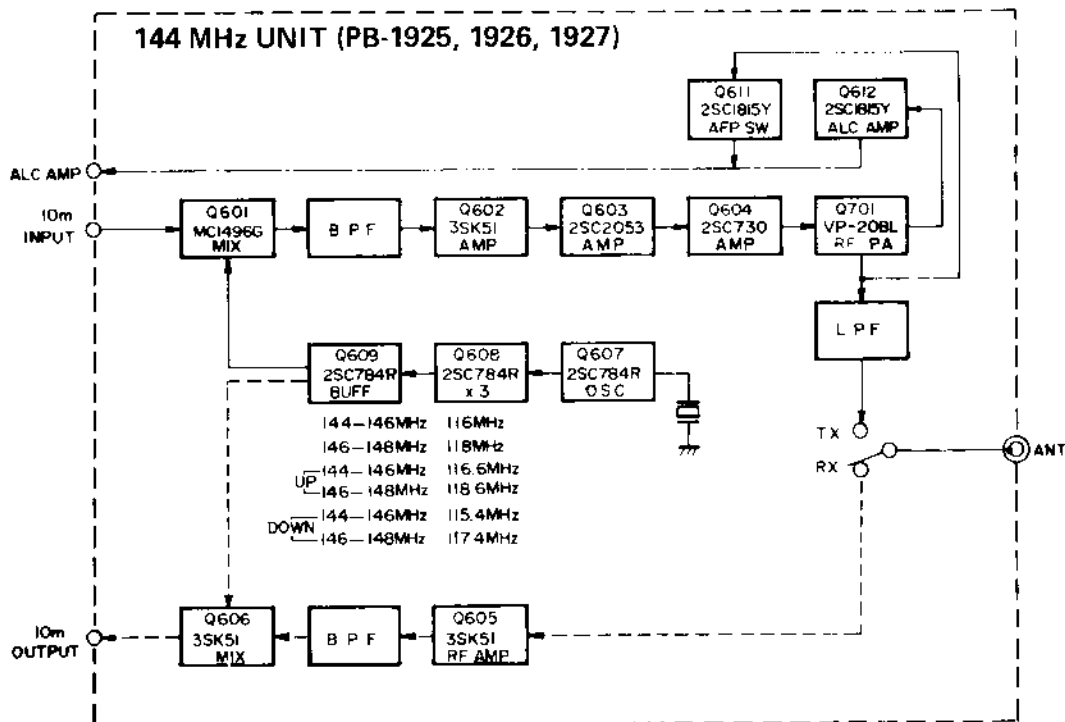

CONVERTER UNIT
(PB1925 NO6..)

Q04 2SC730

Q03 2SC2053

Q02 3SK51

Q01 MC1496G

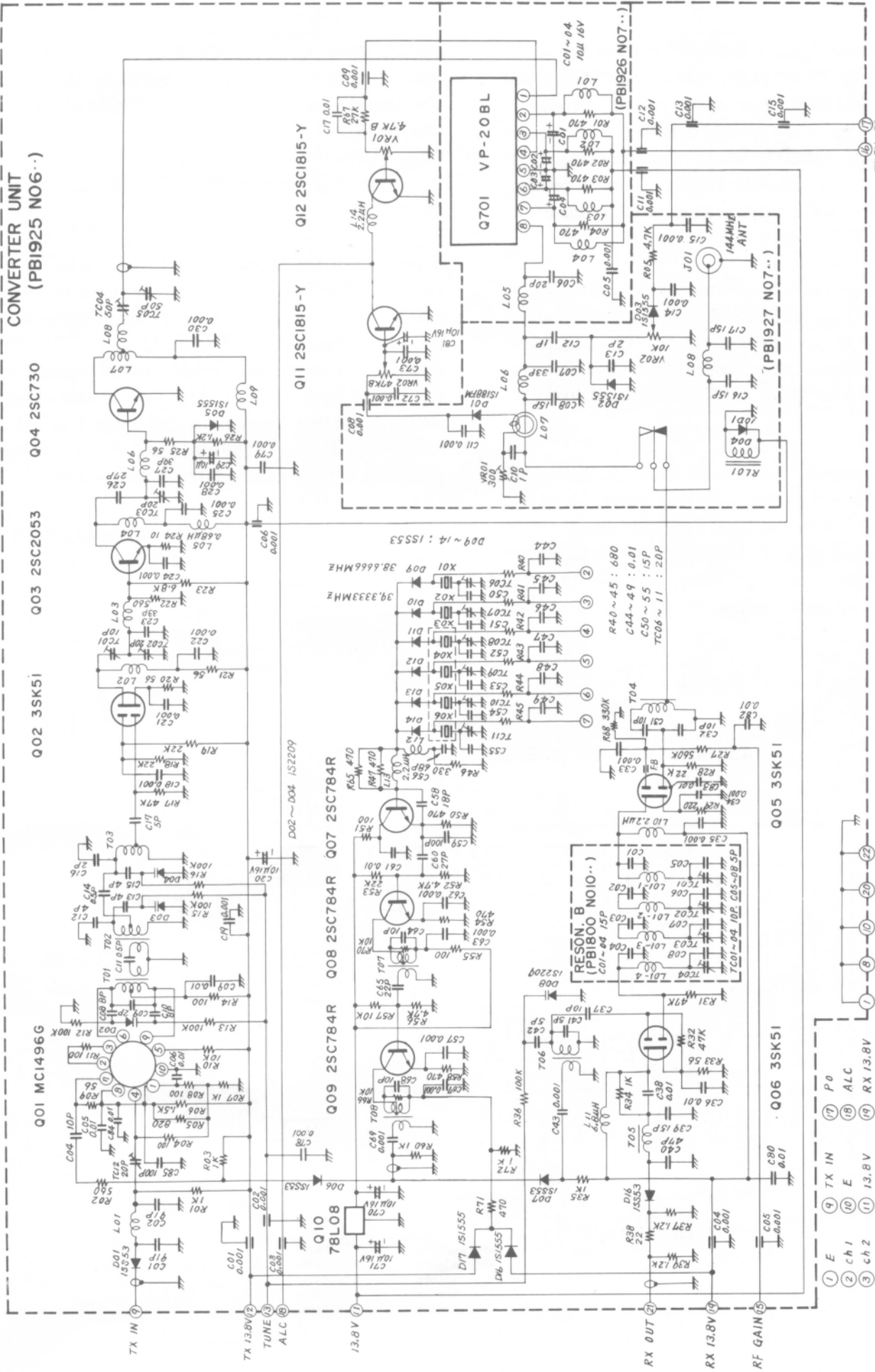

144 MHz UNIT CIRCUIT DIAGRAM

- | | | | | | |
|---|------|----|----------|----|----------|
| 1 | E | 9 | TX IN | 17 | P0 |
| 2 | ch 1 | 10 | E | 18 | ALC |
| 3 | ch 2 | 11 | 13.8V | 19 | RX 13.8V |
| 4 | ch 3 | 12 | TX 13.8V | 20 | E |
| 5 | ch 4 | 13 | TUNE | 21 | RX OUT |
| 6 | ch 5 | 14 | NC | 22 | E |
| 7 | ch 6 | 15 | GAIN | | |
| 8 | E | 16 | TX 8V | | |

430 MHz UNIT

The incoming signal is fed through relay RL₁₃₀₁ to the two stage RF amplifier, consisting of Q₁₂₀₁ and Q₁₂₀₂ (2SC2369), and then passed through a selective filter to the doubly balanced diode mixer, D₁₅₀₃-D₁₅₀₆ (1SS97) where the incoming signal is mixed with a 402-410 MHz local signal, producing a 28-30 MHz output signal which is fed to the 10 M OUTPUT jack.

The local signal is generated at 67-68 MHz by oscillator Q₁₆₀₁ (2SC784R), then multiplied by Q₁₆₀₂ and Q₁₅₀₁ (2SC1424). The local signal at 402-410 MHz is then passed through a selective filter to buffer Q₁₅₀₂ (2SC1424), for delivery to the mixer.

For transmission, the output from the ALC AMP Unit is delivered to the diode ring mixer, where it is heterodyned with the local oscillator signal, resulting in a signal of 430-440 MHz. The signal is then fed through a selective filter, which effectively eliminates spurious responses. The signal is then

amplified by Q₁₂₀₃ (2SC1424), fed through another selective filter, then amplified by the amplifier chain, consisting of Q₁₄₀₁ (2SC1424), Q₁₄₀₂ (2SC1426), Q₁₄₀₃ (2SC1426), and final amplifier Q₁₃₀₁ (UP-07BL). The output signal from Q₁₃₀₁ is fed through a stripline filter, via RL₁₃₀₁, to the ANT jack.

A portion of the output from L₁₃₀₆ is detected by D₁₃₀₂ (1SS97) and fed to the base of Q₁₂₀₅ (2SC1815Y), providing ALC by limiting the drive level from the ALC AMP Unit. Q₁₂₀₄ (2SC1815Y) provides automatic final protection by limiting the drive level from the ALC AMP Unit in case of high SWR. A further portion of the output signal is rectified by D₁₃₀₃ (1S188FM) and fed to the meter, providing indication of relative power output.

The supply voltage for the local oscillator circuit is regulated at 8 volts by Q₁₆₀₃ (78L08).

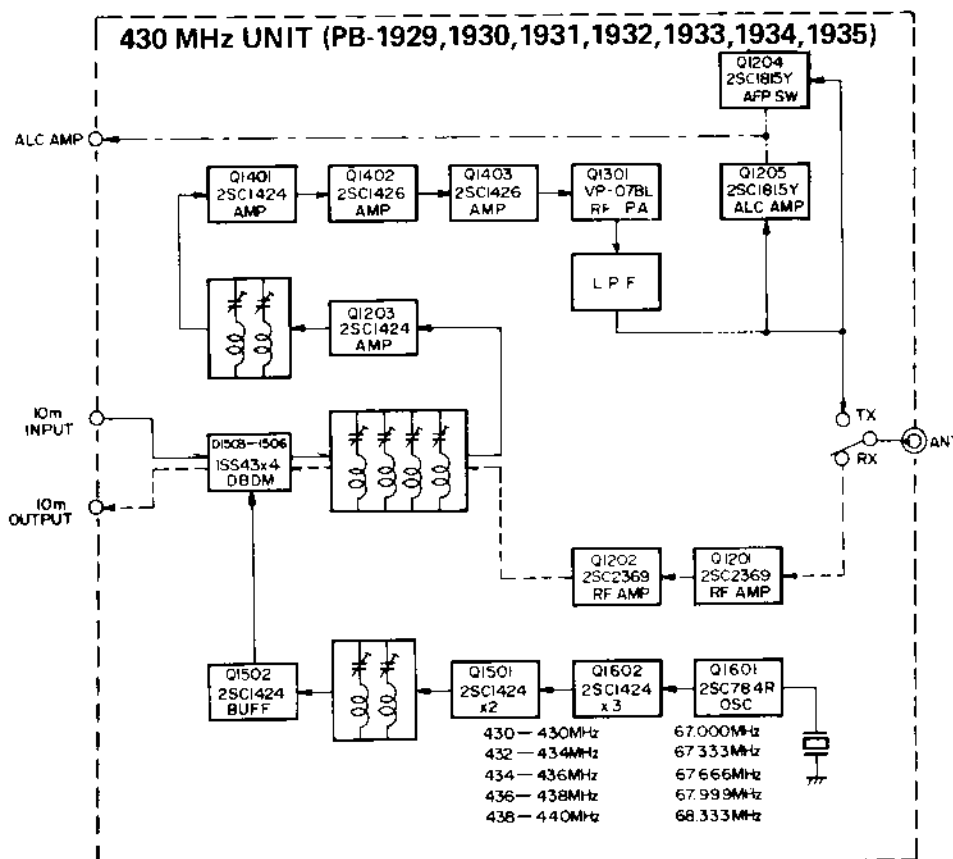

430 MHz UNIT CIRCUIT DIAGRAM

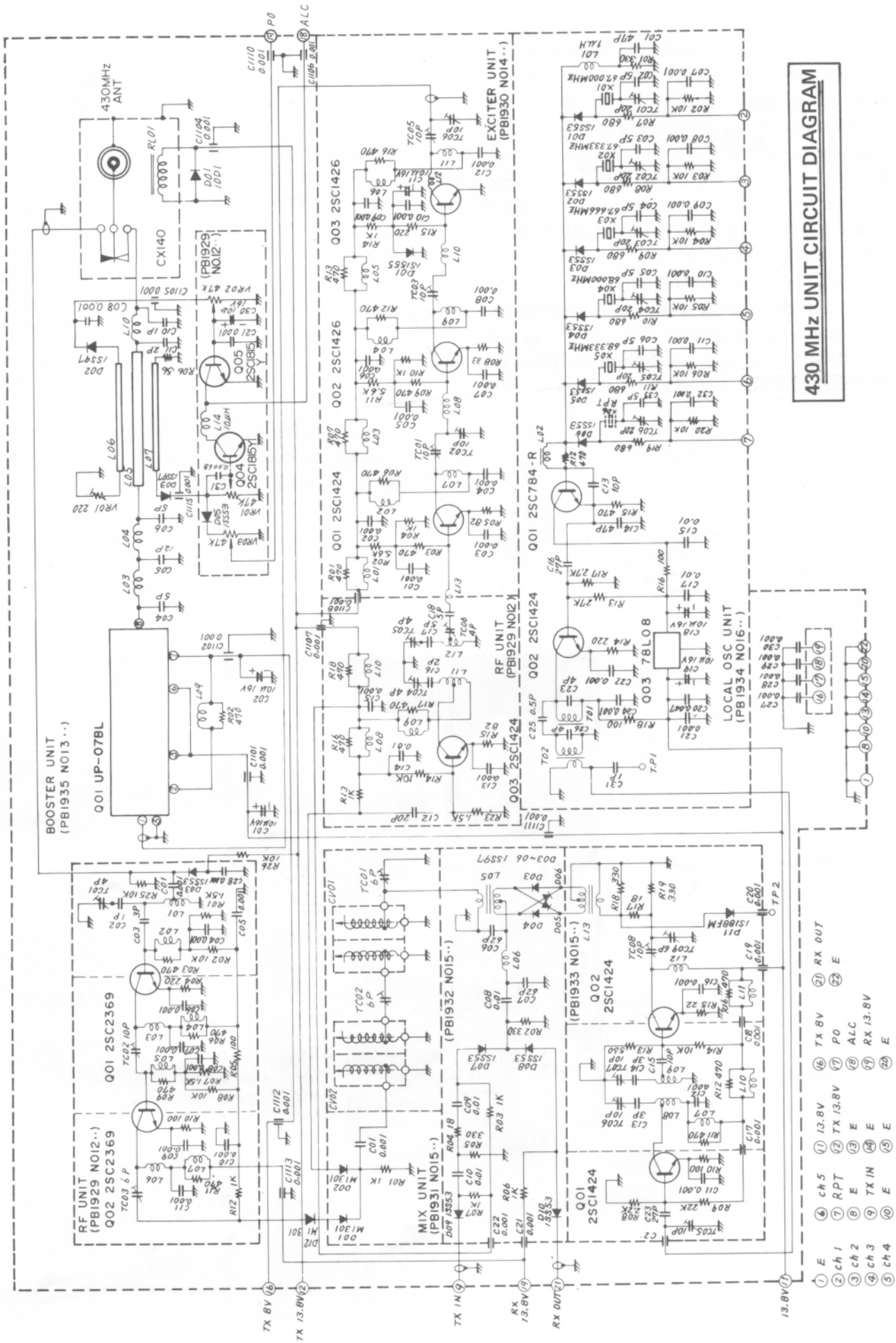

- ① E
- ② ch 1
- ③ ch 2
- ④ ch 3
- ⑤ ch 4
- ⑥ ch 5
- ⑦ RPT
- ⑧ TX 13.8V
- ⑨ E
- ⑩ E
- ⑪ 13.8V
- ⑫ TX 8V
- ⑬ P0
- ⑭ ALC
- ⑮ RX 13.8V
- ⑯ E
- ⑰ RX IN
- ⑱ E
- ⑳ E
- ㉑ RX OUT
- ㉒ E

ALC AMP UNIT

The 28 MHz signal from the transceiver is fed through two sections of pi filter and an attenuator to gate 1 of Q_{2001} (3SK59Y), where the signal is amplified and the amplitude of output is controlled so as not to exceed the level necessary to drive the 50, 144 or 430 MHz unit. The output level of Q_{2001} is controlled to correspond to the ALC voltage delivered from the ALC amplifier. The ALC voltage supplied from the modules is fed to gate 2 of Q_{2001} for gain control purposes. In the AM mode, the ALC level is fixed. A portion of the ALC signal is amplified by amplifiers Q_{2002} (2SK19GR) and Q_{2003} (2SA564Q), providing a DC voltage for the ALC meter.

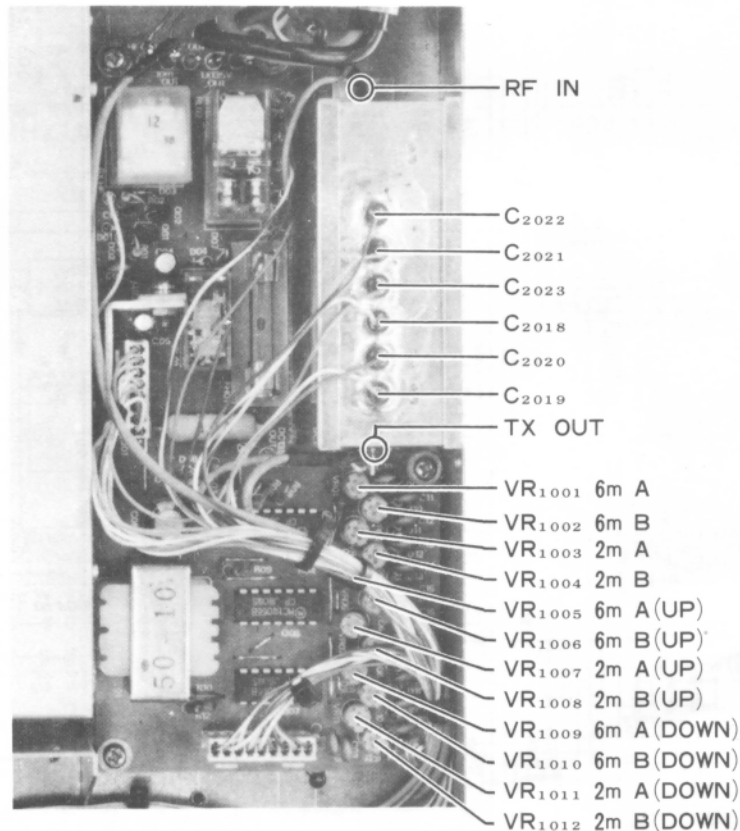

MAINTENANCE AND ALIGNMENT

The FTV-700 has been carefully aligned and tested at the factory prior to shipment. With normal use, if the unit is not abused, the FTV-700 will provide many years of trouble-free operation.

Sudden difficulties are usually the result of part failures, rather than alignment problems. Therefore, alignment should not be undertaken unless the operation of the transverter is completely understood, the fault has been thoroughly diagnosed, and the trouble has been definitely traced to misalignment rather than part failure. Attempts to align this equipment by other than an experienced technician are discouraged.

For alignment purposes, a VTVM with RF probe, a signal generator, a frequency counter, dummy load and wattmeter are required. These must be workable above the highest frequency of the Converter being aligned (55, 150 or 450 MHz).

ALC AMP UNIT (PB-2294)

1. Connect a 1/2-watt 50-ohm resistor to the output terminal of the ALC AMP Unit (in place of any Converter Unit). Set the METER switch to the ALC position, and the ALC switch to the SSB/CW/FM mode.
2. Connect the RF probe of a VTVM to the input terminal of the ALC AMP Unit.
3. Adjust the DRIVE control on the FT-77 front panel so that the VTVM shows 0.22V (rms).
4. Now remove the RF probe from the ALC AMP Unit input terminal and place it on the output terminal of the same unit. Note that this terminal is temporarily terminated by a 50-ohm resistor.
5. Adjust T_{2001} for maximum deflection on the VTVM, and then adjust VR_{2001} to the point where the VTVM reading is 0.11V (rms).
6. Adjust VR_{2004} so that the ALC meter deflects to the full-scale position, then return to the receive condition and adjust VR_{2002} so that the ALC meter indicates exactly zero.

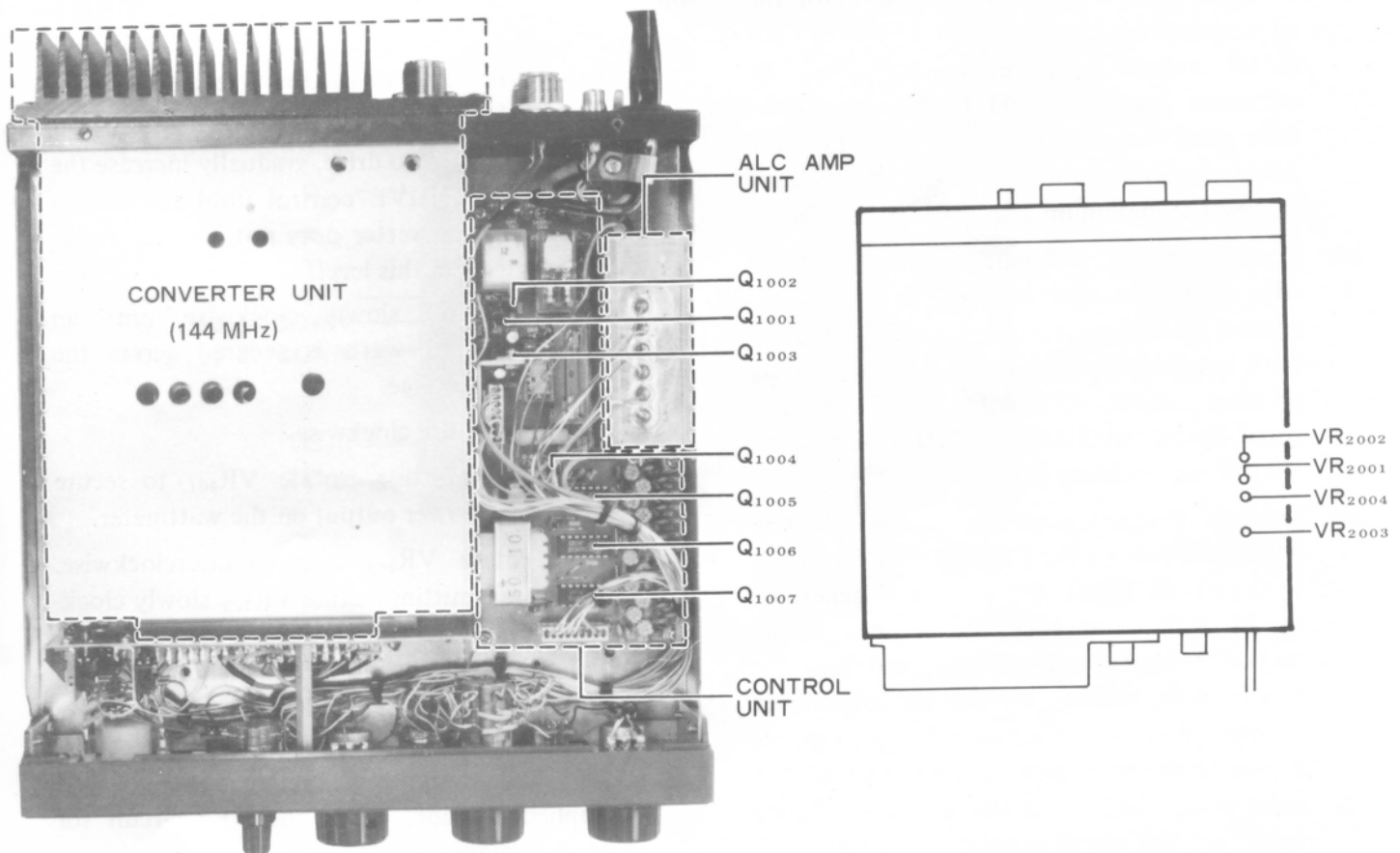

50 MHz UNIT

1. Local oscillator circuit

- (1) Connect the DC voltmeter to pin 2 of the edge connector for the 50 MHz unit. Confirm that 11 volts are present, with the BAND switch set to 0 (50–52 MHz). Switch to 2 (52–54 MHz), and check for 11 volts at pin 3 of the edge connector.
- (2) Connect the RF probe of the VTVM to the LOCAL OUT terminal. Confirm that the unit is oscillating.
- (3) Connect a frequency counter to the LOCAL OUT terminal. Set the BAND switch to 0 (50–52 MHz), set the SHIFT switch to SIMP, and adjust TC₂₀₂ for a reading of exactly 22.0 MHz. Switch to 2 (52–54 MHz), and adjust TC₂₀₃ for a reading of 24.0 MHz.

2. Receiver section

- (1) Set the HF transceiver up for operation on 29 MHz.
- (2) Connect the DC voltmeter to pin 19 of the edge connector, set the BAND switch to 0 (50–52 MHz), then 2 (52–54 MHz), and confirm that 13.5 volts is present.
- (3) Connect the DC voltmeter to pin 15 of the edge connector, and rotate the FTV-700 RF GAIN control fully counterclockwise. The voltmeter reading should be 0 volts. In the fully clockwise position, it should be 11 volts. After confirming these voltages, please leave the level at maximum gain.
- (4) Connect the DC voltmeter to pin 13 of the edge connector, and set the FTV-700 TUNE control to the center position (12 o'clock). With the BAND switch in the 0 (50–52 MHz) position, adjust VR₁₀₀₁ for a reading of 4 volts. Switch to 2 (52–54 MHz), and adjust VR₁₀₀₂ for a reading of 4 volts.
- (5) Connect a signal generator to the 50 MHz ANT jack, and set the FTV-700 BAND switch to 0 (50–52 MHz). Set the signal generator to 51 MHz, and tune the receiver to its output. Peak T₂₀₆, T₂₀₇, T₂₀₈, and T₂₀₉ for a maximum reading on the HF transceiver S-meter. Reduce the signal generator output, if necessary, to secure easy viewing of the peak point. Switch to the 2 (52–54 MHz) band, set the signal generator output to 53

MHz. and repeat these transformers again while tuned to the generator frequency. Then recheck the results at 51 MHz.

3. Transmitter section

- (1) Connect a dummy load/wattmeter to the 50 MHz ANT jack. Set VR₂₀₂ and VR₂₀₃ fully counterclockwise. Set the FT-77 DRIVE control to the center of its range (12 o'clock). Set the BAND switch to 0 (50–52 MHz).
- (2) Connect the RF probe of the VTVM to the collector of Q₂₀₃. While transmitting, peak T₂₀₁, T₂₀₂, T₂₀₃, T₂₀₄, and T₂₀₅ for a maximum reading on the VTVM (0.4 volts RMS nom.).
- (3) Connect the RF probe to terminal A (TX OUT) on the 50 MHz unit. Peak TC₂₀₁ and L₂₀₅ for a maximum reading on the VTVM (4 volts RMS nom.).
- (4) While transmitting, peak TC₃₀₁, TC₃₀₂, TC₃₀₃, TC₃₀₄, and TC₃₀₅ for a maximum power output indication on the wattmeter.
- (5) Repeat steps (2) through (4) on the 2 (52–54 MHz) band. Then recheck the results at 0 (50–52 MHz).
- (6) Set the FTV-700 meter switch to the OUTPUT position, and set the transceiver DRIVE control for an output of 10 watts from the transverter. Set VR₃₀₂ for a reading of .8 on the FTV-700 meter.
- (7) Beginning at zero drive, gradually increase the transceiver DRIVE control until the output from the transverter does not increase more. Do not exceed this level.
- (8) Rotate VR₂₀₂ slowly clockwise, until an output of 10 watts is secured across the 50–54 MHz range.
- (9) Set VR₂₀₃ fully clockwise.
- (10) While transmitting, rotate VR₃₀₁ to secure maximum power output on the wattmeter.
- (11) Now rotate VR₂₀₃ fully counterclockwise. While transmitting, rotate VR₂₀₃ slowly clockwise, until the power output just begins to fall off. Do not go past the threshold point.
- (12) Remove the dummy load from the antenna jack. While transmitting, confirm that the FTV-700 meter indicates .2 with no load applied. If not, check the AFP circuit for malfunctioning parts.

(13) Connect the RF probe of the VTVM to the LOCAL OUT terminal. Set the BAND switch to 0 (50–52 MHz), then switch the SHIFT switch to DOWN. Confirm that oscillation is taking place. Repeat on 2 (52–54 MHz).

(14) Connect the frequency counter to the LOCAL OUT terminal. Adjust TC₂₀₆, TC₂₀₇ as shown in the chart below.

BAND SWITCH	SHIFT SWITCH	ADJUST	FREQUENCY
0	50–52	DOWN	TC ₂₀₆
2	52–54	DOWN	TC ₂₀₇

(15) Set the TUNE control to the center of its range. Adjust the potentiometers for maximum power output while transmitting into the dummy load, as shown in the chart below.

BAND SWITCH	SHIFT SWITCH	ADJUST	RESULT
0	50–52	DOWN	VR ₁₀₀₉
2	52–54	DOWN	VR ₁₀₁₀

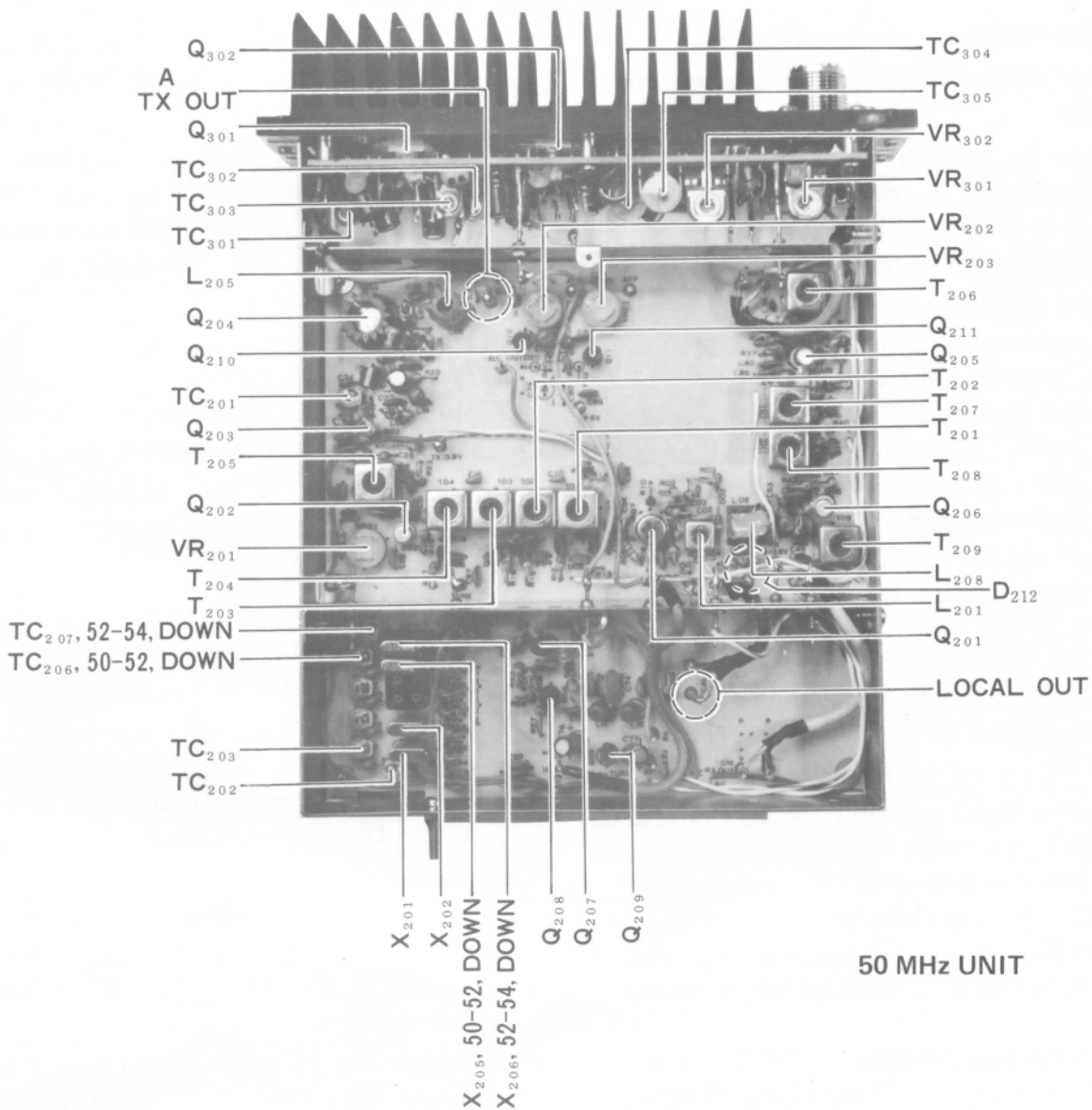
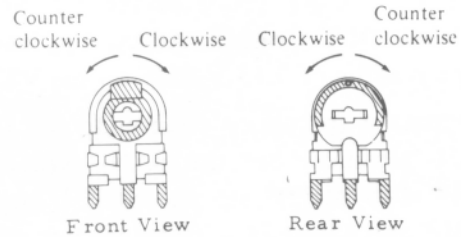

50 MHz UNIT

144 MHz UNIT

1. Local oscillator circuit

- (1) Connect the DC voltmeter to pin 2 of the edge connector for the 144 MHz unit. Confirm that 11 volts is present, with the BAND switch set to 4 (144–146 MHz). Switch to 6 (146–148 MHz), and check for 11 volts at pin 3 of the edge connector.
- (2) Connect the RF probe of the VTVM to the LOCAL OUT terminal. Adjust T_{607} and T_{608} for a reading of 0.15 V RMS on the VTVM.
- (3) Connect a frequency counter to the LOCAL OUT terminal. Set the BAND switch to 4 (144–146 MHz), set the SHIFT switch to SIMP, and adjust TC_{606} for a reading of exactly 116.0 MHz. Switch to 6 (146–148 MHz), and adjust TC_{607} for a reading of 118.0 MHz.

2. Receiver section

- (1) Set the HF transceiver up for operation on 29 MHz.
- (2) Connect the DC voltmeter to pin 19 of the edge connector, set the BAND switch to 4 (144–146 MHz), then 6 (146–148 MHz), and confirm that 13.5 volts is present.
- (3) Connect the DC voltmeter to pin 15 of the edge connector, and rotate the FTV-700 RF GAIN control fully counterclockwise. The voltmeter reading should be 0 volts. In the fully clockwise position, it should be 11 volts. After confirming these voltages, please leave the level at maximum gain.
- (4) Connect the DC voltmeter to pin 13 of the edge connector, and set the FTV-700 TUNE control to the center position (12 o'clock). With the BAND switch in the 4 (144–146 MHz) position, adjust VR_{1003} for a reading of 4 volts. Switch to 6 (146–148 MHz), and adjust VR_{1004} for a reading of 4 volts.
- (5) Connect a signal generator to the 144 MHz ANT jack, and set the FTV-700 BAND switch to 4 (144–146 MHz). Set the signal generator to 145 MHz, and tune the receiver to its output. Peak TC_{1001} – TC_{1004} and T_{604} – T_{606} for a maximum reading on the HF transceiver S-meter.
Reduce the signal generator output, if necessary, to secure easy viewing of the peak point. Switch to the 6 (146–148 MHz) band, set the

signal generator output to 147 MHz, and repeak these transformers again while tuned to the generator frequency. Then recheck the results at 145 MHz.

3. Transmitter section

- (1) Connect a dummy load/wattmeter to the 144 MHz ANT jack. Set VR_{601} and VR_{602} fully counterclockwise. Set the HF transceiver DRIVE control to the center of its range (12 o'clock). Set the BAND switch to 4 (144–146 MHz).
- (2) Connect the RF probe of the VTVM to the collector of Q_{603} . While transmitting, peak T_{601} – T_{603} , TC_{601} , and TC_{602} for a maximum reading on the VTVM (0.9 volts RMS nom.).
- (3) Connect the RF probe to terminal A (TX OUT) on the 144 MHz unit. Peak TC_{604} and TC_{605} for a maximum reading on the VTVM (2.5 volts RMS nom.).
- (4) Repeat steps (2) and (3) on the 6 (146–148 MHz) band. Then recheck the results at 144–146 MHz.
- (5) Set the FTV-700 meter switch to the OUTPUT position, and set the transceiver DRIVE control for an output of 10 watts from the transverter. Set VR_{702} for a reading of .8 on the FTV-700 meter.
- (6) Beginning at zero drive, gradually increase the transceiver DRIVE control until the output from the transverter does not increase more. Do not exceed this level.
- (7) Rotate VR_{601} slowly clockwise, until an output of 10 watts is secured across the 144–148 MHz range.
- (8) Rotate VR_{602} fully clockwise.
- (9) While transmitting, rotate VR_{701} to secure maximum power output on the wattmeter.
- (10) Now rotate VR_{602} fully counterclockwise. While transmitting, slowly rotate VR_{602} clockwise, until the power output just begins to fall off. Do not go past the threshold point.
- (11) Remove the dummy load from the antenna jack. While transmitting, confirm that the FTV-700 meter indicates .2 with no load applied. If not, check the AFP circuit for malfunctioning parts.
- (12) Connect the RF probe of the VTVM to the LOCAL OUT terminal. Set the BAND switch to 4 (144–146 MHz), then switch the SHIFT

switch to UP and DOWN. Confirm that oscillation is taking place. Repeat on 146-148 MHz.

(13) Connect the frequency counter to the LOCAL OUT terminal. Adjust TC₆₀₈-TC₆₁₁ as shown in the chart below.

BAND SWITCH	SHIFT SWITCH	ADJUST	FREQUENCY	
4	144-146	UP	TC ₆₀₈	116.6 MHz
	DOWN	TC ₆₁₀	115.4 MHz	
6	146-148	UP	TC ₆₀₉	118.6 MHz
	DOWN	TC ₆₁₁	117.4 MHz	

(14) Set the TUNE control to the center of its range. Adjust the potentiometers for maximum power output while transmitting into the dummy load, as shown in the chart below.

BAND SWITCH	SHIFT SWITCH	ADJUST	RESULT	
4	144-146	UP	VR ₁₀₀₇	
	DOWN	VR ₁₀₁₁	MAXIMUM OUTPUT	
6	146-148	UP		VR ₁₀₀₈
	DOWN	VR ₁₀₁₂		

(15) Adjust T₆₀₇ and T₆₀₈ for identical power output with the SHIFT switch in the UP and DOWN position.

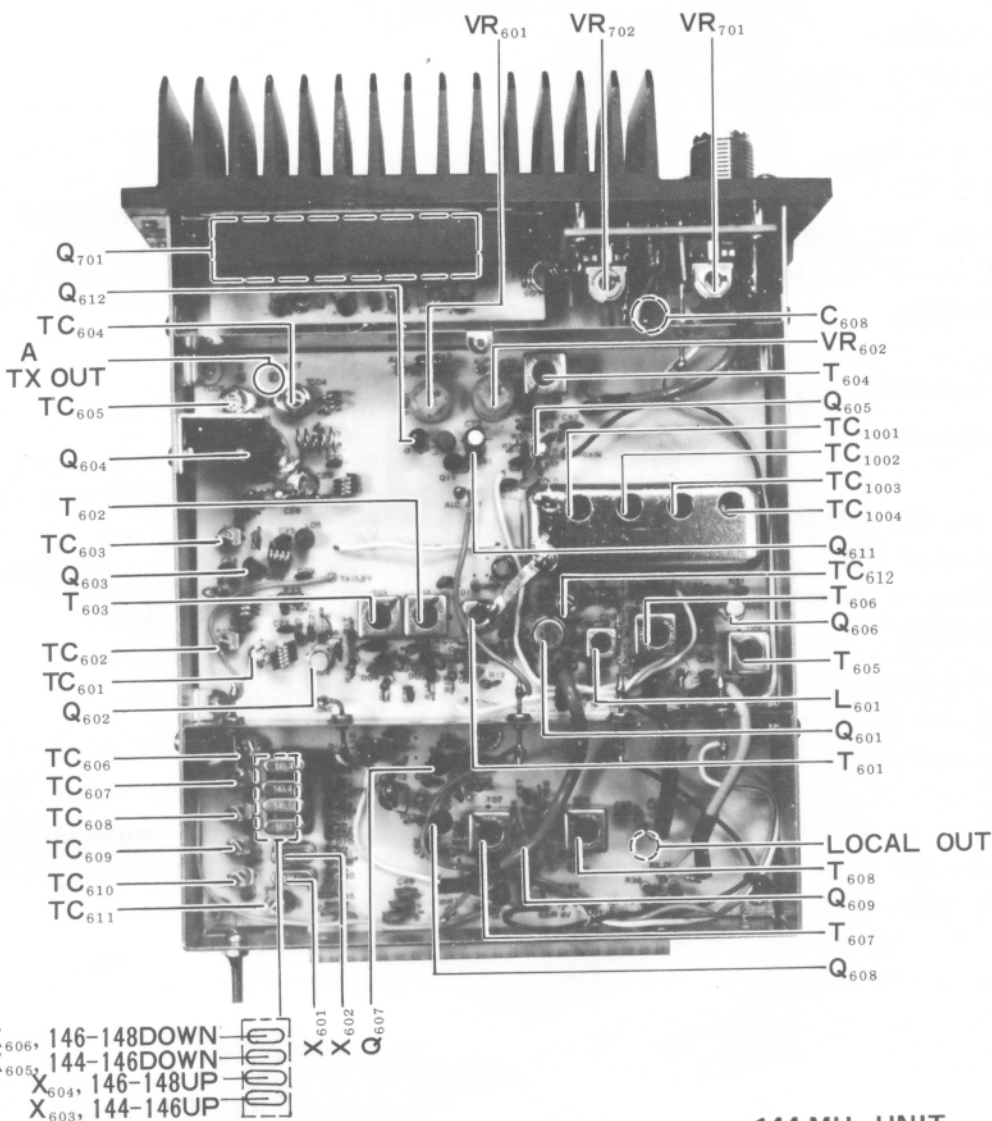

144 MHz UNIT

430 MHz UNIT

1. Local oscillator circuit

- (1) Connect a DC voltmeter to pin 2 of the edge connector for the 430 MHz unit. Set the BAND switch to 0 (430–432 MHz), and confirm that 11 volts is present. In turn, check pins 3, 4, 5, and 6 for 11 volts, while switched to the 2 (432–434 MHz), 4 (434–436 MHz), 6 (436–438 MHz), and 8 (438–440 MHz) bands, respectively.
- (2) Connect the RF probe of the VTVM to TP₁, and adjust L₁₆₀₂, T₁₆₀₁, and T₁₆₀₂ for maximum indication on the VTVM.
- (3) Connect the frequency counter to TP₁. Refer to the chart below, and adjust TC₁₆₀₁–TC₁₆₀₅ for local output readings as shown for the various positions of the BAND switch.

BAND	TRIMMER	FREQ.
0 (430–432 MHz)	TC ₁₆₀₁	201 MHz
2 (432–434 MHz)	TC ₁₆₀₂	202 MHz
4 (434–436 MHz)	TC ₁₆₀₃	203 MHz
6 (436–438 MHz)	TC ₁₆₀₄	204 MHz
8 (438–440 MHz)	TC ₁₆₀₅	205 MHz

- (4) Connect the DC voltmeter to TP₂, and adjust TC₁₅₀₅–TC₁₅₀₉ for maximum indication on the voltmeter (1 volt nom.).

2. Receiver section

- (1) Set the transceiver up for operation on 29 MHz.
- (2) Connect the DC voltmeter to pin 19 of the edge connector, and check for 13.5 volts at each position of the BAND switch over 0–8 (430–440 MHz).
- (3) Connect the signal generator to the 430 MHz ANT jack, set its output to 431 MHz, and tune the receiver to the generator signal. Adjust TC₁₂₀₁–TC₁₂₀₃, TC₁₅₀₁, TC₁₅₀₂, and CV₁₅₀₁/CV₁₅₀₂ for a maximum S-meter indication on the HF transceiver. Repeat on 433 MHz, 435 MHz, 437 MHz, and 439 MHz. Recheck the results to ensure maximum response across the entire operating range.

3. Transmitter section

- (1) Connect the dummy load/wattmeter to the 430 MHz ANT jack. Set VR₁₂₀₁ and VR₁₂₀₂ fully counterclockwise. Set the transceiver DRIVE control to the center of its range (12 o'clock position).
- (2) Connect the RF probe of the VTVM to the anode of D₁₅₀₂. Peak TC₁₅₀₁, TC₁₅₀₂ and CV₁₅₀₁/CV₁₅₀₂ for a maximum indication on the VTVM while transmitting.
- (3) Connect the RF probe of the VTVM to the hot side of L₁₂₁₃. Peak TC₁₂₀₄–TC₁₂₀₆ for a maximum indication on the VTVM while transmitting.
- (4) Connect the RF probe of the VTVM to terminal A (TX OUT) on the 430 MHz unit. Peak TC₁₄₀₁–TC₁₄₀₆ for a maximum indication on the VTVM.
- (5) Confirm the results in steps (2) through (4) on the wattmeter.
- (6) Repeak the points in steps (2) through (5) on each position of the BAND switch, then recheck the results to ensure maximum performance over the entire range 430–440 MHz.
- (7) Set the meter switch to OUTPUT. Set the transceiver DRIVE control for an output of 10 watts. Adjust VR₁₂₀₃ for an indication of .8 on the FTV-700 meter.
- (8) Beginning at zero drive, increase the level of the DRIVE control on the transceiver until the transverter power output does not increase further.
- (9) Advance VR₁₂₀₁ slowly clockwise until equal power output is achieved across the 430–440 MHz range.
- (10) Rotate VR₁₂₀₂ fully clockwise.
- (11) While transmitting, rotate VR₁₃₀₁ to secure maximum power output on the wattmeter.
- (12) Now rotate VR₁₂₀₂ fully counterclockwise. While transmitting, slowly rotate VR₁₂₀₂ clockwise, until the power output just begins to fall off. Do not go past the threshold point.
- (13) Remove the dummy load from the 430 MHz ANT jack. While transmitting, check to be sure that the FTV-700 meter indicates .2 with no load applied. If not, check the AFP unit for malfunctioning parts.

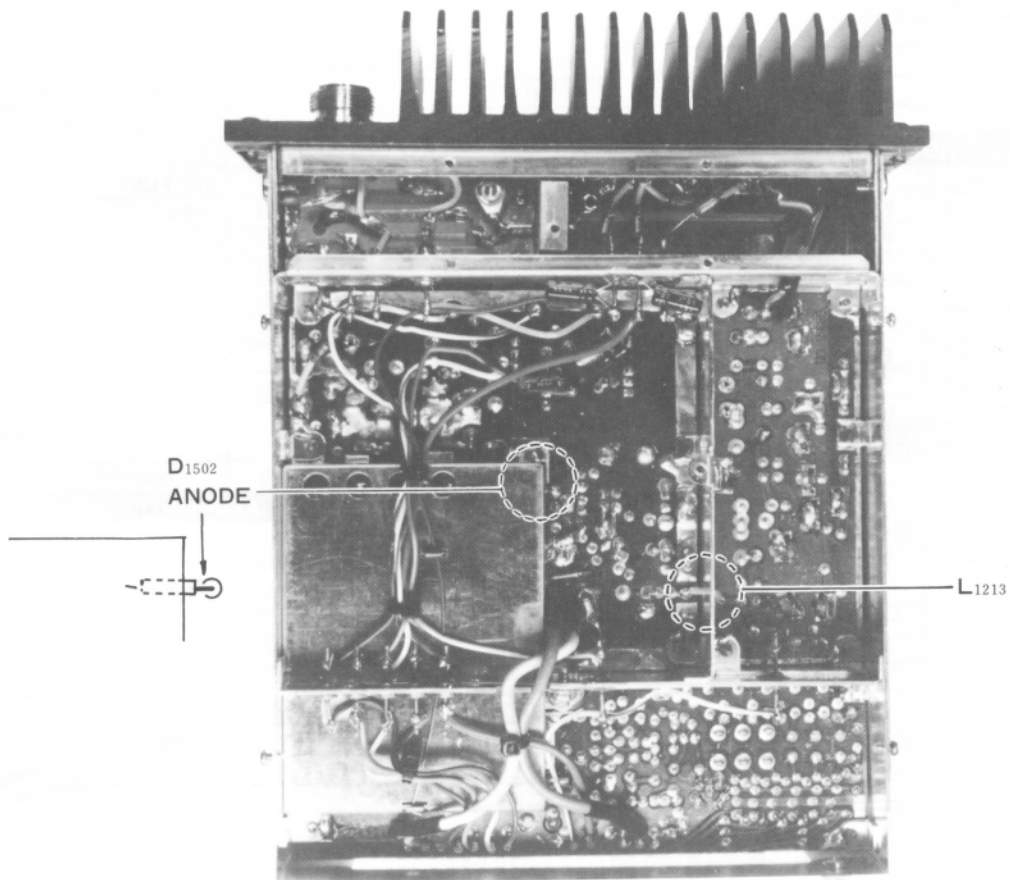
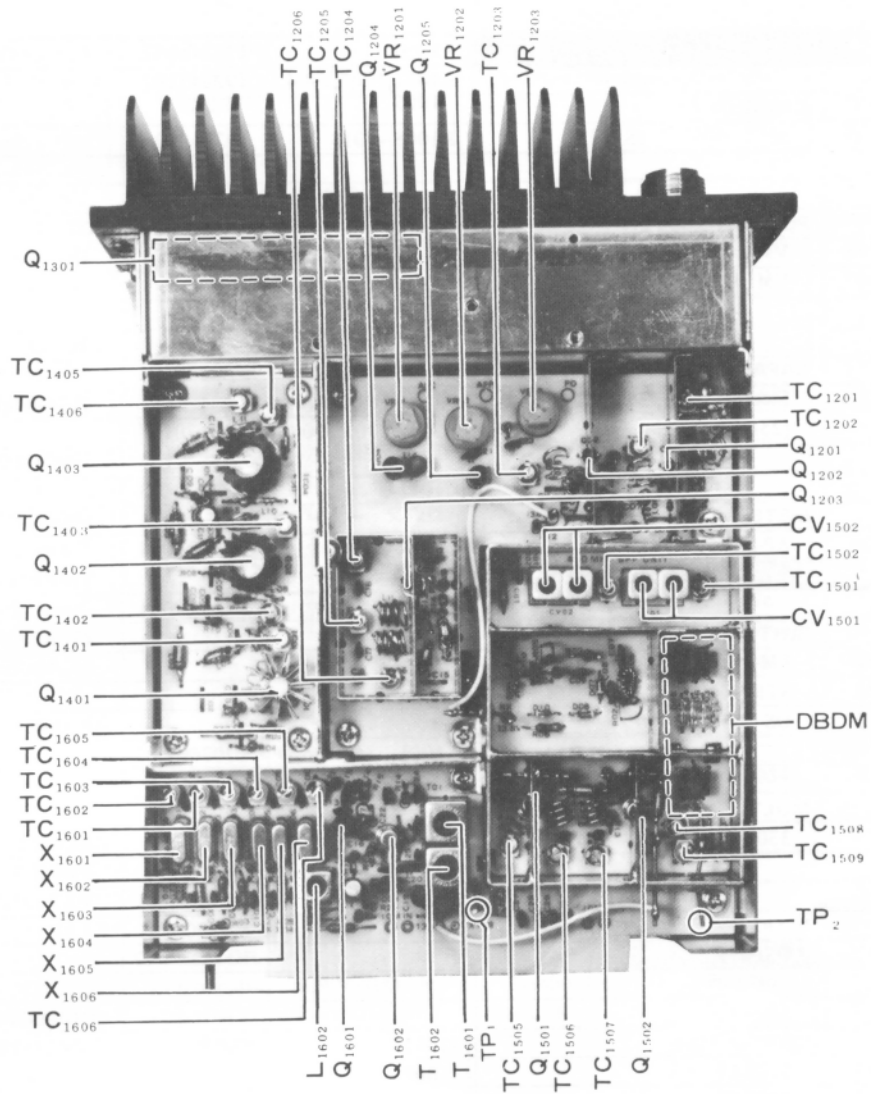

PARTS LIST

MAIN CHASSIS			R1006	J02245102	Carbon film 1/4W SJ 1kΩ
Symbol No.	Part No.	Description	R1001,1002,1004,1005	J02245103	" " " " 10kΩ
D01-05	G2015550	DIODE Si 1S1555	R1008-1013	J02245104	" " " " 100kΩ
		POTENTIOMETER			POTENTIOMETER
VR02	J60800048	VM10A573A-50KB 50kΩB	VR1001-1012	J51745473	H0651A 47kΩB
VR01	J60800047	VM10A573A-100KB 100kΩB			
		CAPACITOR			CAPACITOR
C01	K40149005	Electrolytic 25WV T 1000μF (25RE1000)	C1001	K02179001	Ceramic disc 50WV NPO 1pF (DD104CH010C50V02)
			C1002,1003,1007,1009-1022	K14170103	" " " " 0.01μF (DB201ZF103Z5L5)
			C1023	K13170473	" " " " 0.047μF (DB207YF473Z5L5)
		METER			
M01	M0290026	AP-80	C1004-1006	K40129004	Electrolytic 16WV 10μF (16RE10)
			C1008	K40129001	" " 330μF (16RE330)
		SWITCH			
J01,02	P1090194	FM-MR-M2'			
J03	P1090133	STR01H			
J04	P0090026	QS-1B4M			AF CHOKE
			L1001	L2030019	
		MULTI JACK			RELAY
MJ01	P4090011	3305-022-011	RL1001	M1190006	FBR221D012
			RL1002	M1190029	FBR621D012
			RL1003	M1190030	FBR111D012D
		PLUG			
P01 (with wire)	T9204251	QSP4FK			CONNECTOR
		CONNECTOR	J1001	P0090224	5045-08A
P02 (with wire)	T9204255	5102-08	J1002	P0090225	5045-09A
P03 (with wire)	T9204254	5102-09			
					TERMINAL POST
				Q5000036	TP-G
				Q5000038	TP-I
CONTROL UNIT					DC FUSE
Symbol No.	Part No.	Description	F1001	Q0000005	5A
PB-2290A	F0002290A	Printed Circuit Board			
	C0022900	P.C.B. with components			
		IC & TRANSISTOR	FH1001	P2000003	DC FUSE HOLDER F-3265
Q1001,1002	G3318150G	Transistor 2SC1815GR			
Q1004	G3318150Y	" 2SC1815Y			
Q1005-1007	G1090257	IC MC14066BP			
Q1003	G1090294	" μPC14308			
			ALC AMP UNIT		
Symbol No.	Part No.	Description	Symbol No.	Part No.	Description
D1001-1005, 1009-1020	G2015550	Si 1S1555	PB-2294A	F0002294A	Printed Circuit Board
				C0022940	P.C.B. with components
D1006,1007	G2090001	" 10D1			
D1008	G2090012	Zener WZ110			
		RESISTOR	Q2002	G3090035	FET 2SK19TM-GR
R1007	J31336470	Metallic film 2W 47Ω	Q2001	G4800590Y	3SK59Y
R1003	J02245101	Carbon film 1/4W SJ 100Ω			

		TRANSISTOR		DIODE UNIT			
Q2003	G3105641Q	2SA564AQ		Symbol No.	Part No.	Description	
				PB-2291	F0002291	Printed Circuit Board	
					C0022910	P.C.B. with components	
		DIODE					
D2003	Q2015550	Si	1S1555				
D2001	G9090005	Varistor	MV103			DIODE	
D2002	G2090009	Zener	WZ081	D3101,3103	G2015550	Si 1S1555	
		RESISTOR				RESISTOR	
R2001	J02245560	Carbon film	1/4W SJ 56Ω	R3101	J01245562	Carbon film 1/4W TJ 5.6kΩ	
R2002	J02245820	" "	" " 82Ω	R3102	J01245683	" " " " 68kΩ	
R2006	J02245331	" "	" " 330Ω				
R2007,2015,2017	J02245102	" "	" " 1kΩ				
R2005,2016	J02245152	" "	" " 1.5kΩ				
R2009,2010	J02245562	" "	" " 5.6kΩ				
R2008,2011,2013,2014	J02245103	" "	" " 10kΩ				
		SW UNIT A					
R2003	J02245473	" "	" " 47kΩ	Symbol No.	Part No.	Description	
R2004	J02245224	" "	" " 220kΩ	PB-2292	F0002292	Printed Circuit Board	
R2012	J02245565	" "	" " 5.6MΩ		C0022920	P.C.B. with components	
		POTENTIOMETER				SWITCH	
VR2001	J50702501	EVL-S0AA00B52	500ΩB	S3201	N4090034	SUT31A	
VR2004	J50702202	EVL-S0AA00B23	2kΩB				
VR2003	J50702203	EVL-S0AA00B24	20kΩB				
VR2002	J50702503	EVL-S0AA00B54	50kΩB				
		CAPACITOR				SW UNIT B	
C2009	K02175180	Ceramic disc	50WV NPO 18pF (DD104CH180J50V02)	Symbol No.	Part No.	Description	
				PB-2293	F0002293	Printed Circuit Board	
C2001,2003,2012	K02179019	" "	" " 91pF (DD107CH910J50V02)		C0022930	P.C.B. with components	
C2010	K02179020	" "	" " 110pF (DD108CH111J50V02)			LED	
C2002,2011	K02179023	" "	" " 180pF (DD110CH181J50V02)	D3301	G2090134	TLY-25	
C2004-2008,2014,2017,2024	K14170103	" "	" " 0.01μF (DD106FZ103Z50V02)			RESISTOR	
C2013	K70167104	Tantalum	35WV 0.1μF (CS15E1V0R1M1S)	R3301	J02245152	Carbon film 1/4W SJ 1.5kΩ	
C2015,2016	K40129004	Electrolytic	16WV 10μF (16RE10)			SWITCH	
C2018-2023	K21170002	Feed through	50WV 0.001μF (ECK-Y1H102WE)	S3301	N4090035	SUT12A	
		INDUCTOR					
L2001,2002,2005,2006	L0020535					ACCESSORIES	
L2003,2004	L1190029	FLSH-470K		Symbol No.	Part No.	Description	
					T9100071A	Connection cable A	
					T9100160A	" " B	
					T9101272	Speaker cord	
		TRANSFORMER					
T2001	L0020180	R12-4434			R6052652	Spacer	
	Q5000011	Wrapping terminal C			Q0000005	Spare Fuse 5A	
	Q4000001	Hermetic seal					

50 MHz UNIT (OPTION)			R256	J00245823	Carbon film 1/4W VJ 82k Ω
Symbol No.	Part No.	Description	R212,213, 215-217,220, 239,240	J00245104	" " " " 100k Ω
	C0019220	50MHz UNIT			
			R222,233	J01245104	" " " TJ 100k Ω
***** MAIN CHASSIS *****					
			R218	J00245224	" " " VJ 220k Ω
C101-106, 108-114	K21170002	Ceramic Feed Thru 0.001 μ F (ECK-Y1H102WE)	R264	J01245334	" " " TJ 330k Ω
			R236	J00245564	" " " VJ 560k Ω
			R265	J00245335	" " " " 3.3M Ω
					POTENTIOMETER
			VR201-203	J51723473	SR19RS 47k Ω B
***** 50 MHz CONVERTER MAIN BOARD *****					
	F0001922	Printed Circuit Board			
	C9019220	PCB with Components			CAPACITOR
			C213,245	K00179001	Ceramic disc 50WV SL 0.5pF (DD104SL0R5C50V02)
		IC, FET, TRANSISTOR			
			C222,242	K02279001	" " " CH 1pF (ECC-D2H010DC)
Q201	G1090061	IC MC1496G	C211,215,218,236, 243,278	K02172050	" " " " 5pF (DD104CH050C50V02)
Q209	G1090123	" 78L08			
Q202,205,206	G4800510C	FET 3SK51-03	C203,210	K00173100	" " " SL 10pF (DD104SL100D50V02)
Q203	G3320530	Transistor 2SC2053			
Q204	G3307300	" 2SC730	C237,247,251	K02173100	" " " CH 10pF (DD104CH100D50V02)
Q207,208	G3307840R	" 2SC784R			
Q210,211	G3318150Y	" 2SC1815Y	C249	K02175150	" " " " 15pF (DD104CH150J50V02)
		DIODE	C228	K00175180	" " " SL 18pF (DD104SL180J50V02)
D201,202,212,213	G2090027	Silicon 1SS53	C216	K00179005	" " " " 20pF (DD104SL200J50V02)
D208,214-219, 221	G2015550	" 1S1555			
D203-207, 209-211	G2022090	Varactor 1S2209	C219	K00175220	" " " " 22pF (DD104SL220J50V02)
			C260-265,269	K02179009	" " " CH 22pF (DD104CH220J50V02)
				K00175330	" " " SL 33pF (DD104SL330J50V02)
		CRYSTAL			
X201	H0101330	HC-18/U 22.0MHz	C204,233,234	K00175470	" " " " 47pF (DD104SL470J50V02)
X202	H0101340	" 24.0MHz			
X206	H0101360	" 23.0MHz	C212,214,217,250, 246	K02175470	" " " CH 47pF (DD106CH470J50V02)
X205	H0101350	" 21.0MHz			
			C223,235,238,241, 244	K06175470	" " " UJ 47pF (ECC-D1H470JU2)
		CRYSTAL SOCKET			
XS201	P3090029	S-14-4P	C201,202	K00179013	" " " SL 91pF (DD104SL910J50V02)
			C225,273,275	K00175101	" " " " 100pF (DD105SL101J50V02)
		RESISTOR			
R226	J00245100	Carbon film 1/4W VJ 10 Ω	C207,208,267,268	K02175101	" " " CH 100pF (DD107CH101J50V02)
R207,230	J00245560	" " " " 56 Ω			
R204,209,211,214, 223,255,258	J00245101	" " " " 100 Ω		K00175121	" " " SL 120pF (DD105SL121J50V02)
R221,237,243	J00245221	" " " " 220 Ω	C274	K00179019	" " " " 200pF (DD106SL201J50V02)
R224	J00245271	" " " " 270 Ω			
R202,254	J00245471	" " " " 470 Ω	C232,252,266	K12171102	" " " " 0.001 μ F (DD105E102P50V02)
R205	J01245821	" " " TJ 820 Ω			
R201,203,208,238, 244,251,257,259	J00245102	" " " VJ 1k Ω	C205,206,209,220, 221,224,226,227, 230,231,239,240, 248,253-259, 270-272, 283-288,292	K14170103	" " " " 0.01 μ F (DD106FZ103Z50V02)
R229	J00245122	" " " " 1.2k Ω			
R206,245-250	J00245152	" " " " 1.5k Ω			
R225	J00245332	" " " " 3.3k Ω			
R210,252,253	J00245103	" " " " 10k Ω	C291	K50177682	Mylar 50WV 0.0068 μ F (50F2U682M)
R235	J00245223	" " " " 22k Ω			
R219	J00245393	" " " " 39k Ω	C229,276,277,290	K40120106	Electrolytic 16WV 10 μ F (16RL10)
R241,242	J00245473	" " " " 47k Ω			

		TRIMMER CAPACITOR	VR302	J50702103	EVL-S0AA00B14	10kΩB
TC201-207	K91000029	ECV1ZW 20 x 53N 20pF				
		TRANSFORMER	C334	K00179001	CAPACITOR	
T201-208	L0020408				Ceramic disc 50WV SL 0.5pF	(DD104SL0R5C50V02)
T209	L0020166	R12-4180	C316,335	K00172010	" " " " 1pF	(DD104SL010C50V02)
		INDUCTOR	C310,315	K00172050	" " " " 5pF	(DD104SL050C50V02)
L211,212	L1190004	FL4H-R68M 0.68μH	C302	K00179005	" " " " 20pF	(DD104SL200J50V02)
L214	L1190009	FL4H-3R3M 3.3μH			" " " " 33pF	(DD104SL330J50V02)
L207,209	L1190013	FL4H-6R8K 6.8μH	C301,317	K00175330	" " " " 39pF	(DD104SL390J50V02)
L213	L1190014	FL4H-100K 10μH	C307	K00175390	" " " " 47pF	(DD104SL470J50V02)
L210	L1190017	FL5H-102K 1mH			" " " " 62pF	(DD104SL620J50V02)
L208	L0020209		C320,329	K00175470	" " " " 82pF	(DD104SL820J50V02)
L202,204,206	L1020324				" " " " 100pF	(DD105SL101J50V02)
L203	L0020416A		C323	K00179011	" " " " 120pF	(DD105SL121J50V02)
L201	L0020535		C314,324	K00175820	" " " " 0.01μF	(DD106FZ103Z50V02)
L205	L0190003	IFT-51S10-H3				
		FERRITE BEADS	C321,328	K00175101		
	L9190001	Ri 3 x 3-1	C319	K00175121		
	Q5000025	Wrapping terminal A	C304,306,309,311,313,318,326,327,331,333	K14170103		
		HEAT SINK	C303,305,308,312,330,332	K40120226	Electrolytic 16WV TW 22μF (16RL22)	
	R5047915B	T0-5, L = 20 mm				
					INDUCTOR	
			L314	L1190003	EL0710-100K	10μH
***** 50 MHz BOOSTER BOARD *****						
PB-1923B	I0001923B	Printed circuit board	L304,313	L0020196		
	C9019230A	PCB with components	L302,305	L0020324		
			L301	L0020527		
			L303,306	L0020528		
			L307	L0020529		
		TRANSISTOR	L308-310,312	L0020530		
Q301	G3321660	Transistor 2SC2166	L311	L0020584		
Q302	G3319450D	" 2SC1945D				
		DIODE	TC301	K91000020	TRIMMER CAPACITOR	
D301,302,308	G2090001	Silicon 10D1	TC302,303	K91000023	ECV-1ZW 20 x 40N 20pF	
D307	G2001880F	Germanium 1S188FM	TC304,305	K91000058	ECV-1ZW 50 x 40N 50pF	
D303-306	G2015550	Silicon 1S1555			2222-808-61809 80pF	
		RESISTOR	RL301	M1190006	RELAY	
R303	J10276560	Carbon composition 1/2W GK 56Ω			FBR-221D012	
R306	J10276101	" " " " 100Ω			CONNECTOR	
R305	J10276151	" " " " 150Ω	J301	P1090026	SO-239	
R302	J10276221	" " " " 220Ω				
R301,304 (L302,305)	J10276471	" " " " 470Ω		Q5000025	Wrapping terminal A	
R308	J01245102	Carbon film 1/4W TJ 1kΩ		R4050740	Booster heat sink	
R307	J00245103	" " " VJ 10kΩ				
		POTENTIOMETER				
VR301	J50702301	EVL-S0AA00B32 300ΩB				

144 MHz UNIT (OPTION)			R646	J00245331	Carbon film 1/4W VJ 330Ω
Symbol No.	Part No.	Description	R647 (L613)	J10276471	Carbon composition 1/2W GK 470Ω
	C0019250A	144MHz UNIT	R665,671	J01245471	Carbon film 1/4W TJ 470Ω
			R650,654,658	J00245471	" " " VJ 470Ω
			R602,622	J00245561	" " " " 560Ω
			R640-645	J00245681	" " " " 680Ω
			R605	J01245821	" " " TJ 820Ω
			R601,603,607,634, 635,660,672	J00245102	" " " VJ 1kΩ
			R626,637,639	J00245122	" " " " 1.2kΩ
			R606	J00245152	" " " " 1.5kΩ
			R652,656	J00245472	" " " " 4.7kΩ
			R623	J01245682	" " " TJ 6.8kΩ
			R610,657,666,670	J00245103	" " " VJ 10kΩ
			R618,619,628,653	J00245223	" " " " 22kΩ
			R667	J00245273	" " " " 27kΩ
			R617,631,632	J00245473	" " " " 47kΩ
			R612,613,615,616, 636	J00245104	" " " " 100kΩ
			R668	J01245334	" " " TJ 330kΩ
			R627	J00245564	" " " VJ 560kΩ
			R669	J01245225	" " " TJ 2.2MΩ
***** MAIN CHASSIS *****					
C501-506,508, 509,511-513, 515	K21170002	Ceramic feed thru (ECK-Y1H102WE) 0.001μF			
C517	K50177103	Mylar 50WV 0.01μF (50F2U103M)			
***** 144 MHz CONVERTER MAIN BOARD *****					
PB-1925A	F0001925A	Printed circuit board			
	C9019250A	PCB with components			
		IC, FET, TRANSISTOR			
Q601	G1090061	IC MC-1496G			
Q610	G1090123	" 78L08			
Q602,605,606	G4800510C	FET 3SK51-03			
Q604	G3307300	Transistor 2SC730			
Q607-609	G3307840R	" 2SC784R	VR601	J51723472	POTENTIOMETER SR19RS 4.7kΩB
Q611,612	G3318150Y	" 2SC1815Y	VR602	J51723473	SR19RS 47kΩB
Q603	G3320530	" 2SC2053			
					CAPACITOR
D601,606,607, 609-614,616	G2090027	Silicon 1SS53	C614	K00179001	Ceramic disc 50WV SL 0.5pF (DD104SL0R5C50V02)
D605,617,618	G2015550	" 1S1555	C609	K02179001	" " " CH 1pF (DD104CK010C50V02)
D602-604,608	G2022090	Varactor 1S2209	C612,616	K02179003	" " " " 2pF (DD104CK020C50V02)
			C613,615	K06172040	" " " UJ 4pF (ECC-D1H040CU)
		CRYSTAL	C611,617	K00172050	" " " SL 5pF (DD104SL050C50V02)
X601	H0101380	HC-18/U 38.6666MHz	C641	K02172050	" " " CH 5pF (DD104CH050C50V02)
X602	H0101390	" 39.3333MHz	C642	K06172050	" " " UJ 5pF (ECC-D1H050CU)
X603	H0101400	HC-25/U (600kHz SHIFT) 38.8666MHz	C608,610	K06173080	" " " " 8pF (DD104UJ080D50V02)
X604	H0101420	" (" ") 39.5333MHz	C604,637	K00713100	" " " SL 10pF (DD104SL100D50V02)
X605	H0101410	" (" ") 38.4666MHz	C631,632,664,668	K02173100	" " " CH 10pF (DD104CH100D50V02)
X606	H0101430	" (" ") 39.1333MHz	C650-655	K02175150	" " " " 15pF (DD104CH150J50V02)
X603*	H0101405	HC-25/U (700kHz SHIFT) 38.9000MHz	C639	K00175150	" " " SL 15pF (DD104SL150J50V02)
X604*	H0101406	" (" ") 38.4333MHz	C658	K02175180	" " " CH 18pF (DD104CH180J50V02)
X605*	H0101407	" (" ") 39.5666MHz	C665	K00175220	" " " SL 22pF (DD104SL220J50V02)
X606*	H0101408	" (" ") 39.1000MHz	C626	K00175270	" " " " 27pF (DD104SL270J50V02)
			C660	K02179011	" " " CH 27pF (DD104CH270J50V02)
			C623	K00175330	" " " SL 33pF (DD104SL330J50V02)
		CRYSTAL SOCKET			
XS601	P3090029	S-14-4P			
		RESISTOR			
R624	J00245100	Carbon film 1/4W VJ 10Ω			
R638	J00245220	" " " " 22Ω			
R609,620,621,633	J00245560	" " " " 56Ω			
R625	J00245680	" " " " 68Ω			
R604,608,611,614, 651,655,659	J00245101	" " " " 100Ω			
R629	J00245221	" " " " 220Ω			

			***** 144 MHz BOOSTER BOARD *****		
C627	K00175390	Ceramic disc 50WV SL 39pF (DD104SL390J50V02)	PB-1926	F0001926	Printed circuit board
C640	K00175470	" " " " 47pF (DD104SL470J50V02)	PB-1927	C9019260	PCB with components
C656	K02175680	" " " CH 68pF (DD107CH680J50V02)		F0001927	Printed circuit board
C601,602	K00179013	" " " SL 91pF (DD104SL910J50V02)		C9019270	PCB with components
C685	K00175101	" " " " 100pF (DD105SL101J50V02)	Q701	G1090216	POWER MODULE VP-20BL
C659	K02175102	" " " CH 100pF (DD107CH101J50V02)			DIODE
C607,618,619,621, 622,624,625,628, 630,633-635, 643,657,662,663, 667,669,672,673, 678,679	K12171102	" " " " 0.001μF (DD105E102P50V02)	D704	G2090001	Silicon 10D1
			D701	G2001880F	Germanium 1S188FM
			D702,703	G2015550	Silicon 1S1555
C605,606,636,638, 644-649,661, 680,682-684	K13170103	" " " " 0.01μF (DB201YF103Z5L5)			RESISTOR
			R705	J00245472	Carbon film 1/4W VJ 4.7kΩ
			R701(L701), 704(L704)	J10276471	Carbon composition 1/2W GK 470Ω
C620,629,670,671, 681	K40120106	Electrolytic 16WV TW 10μF (16RL10)	R702(L702), 703(L703)	J10246471	" " 1/4W " 470Ω
		TRIMMER CAPACITOR			
TC601	K91000028	ECV-1ZW 10 x 53N 10pF			POTENTIOMETER
TC602,603, 606-612	K91000029	ECV-1ZW 20 x 53N 20pF	VR701	J50702301	EVL-S0AA00B32 300ΩB
			VR702	J50702103	EVL-S0AA00B14 10kΩB
TC604,605	K91000016	ECV-1ZW 50 x 32N 50pF			
		INDUCTOR			CAPACITOR
L605	L1190004	FL4H-R68M 0.68μH	C710,712	K00172010	Ceramic disc 50WV SL 1pF (DD104SL010C50V02)
L610,612,614	L1190008	FL4H-2R2M 2.2μH	C713	K00172020	" " " " 2pF (DD104SL020C50V02)
L611	L1190013	FL4H-6R8K 6.8μH	C708,716,717	K00175150	" " " " 15pF (DD104SL150J50V02)
L606,608	L0020193				
L602	L0020195				
L603,604,609	L0020196		C706	K00179005	" " " " 20pF (DD104SL200J50V02)
L613	L0020206				
L607	L0020380		C707	K00175330	" " " " 33pF (DD104SL330J50V02)
L601	L0020535				
			C705,711,714,715	K12171102	" " " " 0.001μF (DD105E102P50V02)
		TRANSFORMER	C701-704	K40120106	Electrolytic 16WV TV 10μF (16RL10)
T604	L0020105	R12-4091			
T602,603, 606-608	L0020111	R12-4102			
T605	L0020166	R12-4180			INDUCTOR
T601	L0020536		L707	L0020069	
			L701,704	L1020324	
			L706,708	L0020430	
		HEAT SINK	L702,703	L1020469	
	R5047915B	TO-5, L = 20 mm	L705	L0020654	
		FERRITE BEADS			RELAY
	L9190001	Ri 3 x 3-1	RL701	M1190006	FBR-221D012
	Q5000025	Wrapping terminal A			
					RECEPTACLE
			J701	P1090026	SO-239
				Q5000025	Wrapping terminal A

***** RESONATOR BOARD *****			R1202,1208,1214, 1225	J00245103	Carbon film 1/4W VJ 10kΩ
PB-1800	F0001800	Printed circuit board			
	C9018000	PCB with components			
					POTENTIOMETER
		CAPACITOR	VR1201-1203	J51723473	SR19RS 47kΩB
C1005-1008	K02172050	Ceramic disc 50WV CH 5pF (DD104CH050C50V02)			
C1001-1004	K02175150	" " " " 15pF (DD104CH150J50V02)	C1202	K02179001	CAPACITOR Ceramic disc 50WV CH 1pF (DD104CK010C50V02)
		TRIMMER CAPACITOR	C1203	K00172030	Ceramic disc 50WV SL 3pF (DD104SL030C50V02)
TC1001-1004	K91000028	ECV-1ZW 10 x 53N 10pF	C1216,1218	K02172050	" " " CH 5pF (DD104CH050C50V02)
		INDUCTOR	C1212	K02179008	" " " " 20pF (DD104CH200J50V02)
L1001	L0020409		C1201,1221,1229	K12171102	" " " " 0.001μF (DD105E102P50V02)
	R0044940A	Resonator case			
	Q5000011	Wrapping terminal C	C1204-1211,1213, 1215,1228	K22170001	" " " " 0.001μF (HDC60E102M)
			C1214,1226	K23140001	" chip 25V 0.01μF (GR42Y5V103Z25V)
			C1231	K50177682	Mylar 50WV 0.0068μF (501-2U682M)
			C1230	K40120106	Electrolytic 16WV TW 10μF (16RL10)
430 MHz UNIT (OPTION)					
Symbol No.	Part No.	Description			
	C0019290	430MHz UNIT			
					TRIMMER CAPACITOR
			TC1201, 1204-1206	K91000059	ECV-1ZW 04 x 53N 4pF
C1101-1108, 1110-1115	K21170002	Ceramic feed thru 0.001μF (ECK-Y1H102WE)	TC1203	K91000055	ECV-1ZW 06 x 53N 6pF
			TC1202	K91000028	ECV-1ZW 10 x 53N 10pF
					INDUCTOR
			L1214	L1190014	FL4H-100K 10μH
			L1202,1204,1205, 1207-1209	L1020469	
***** 430 MHz RF BOARD *****					
PB-1929	F0001929	Printed circuit board	L1211,1212	L0020471	
	C9019290	PCB with components	L1203,1206	L0020472	
				L0020474	
		TRANSISTOR	L1201	L0020523	
Q1203	G3314240	Transistor 2SC1424			
Q1204,1205	G3318150Y	" 2SC1815Y		Q5000011	Wrapping terminal C
Q1201,1202	G3323690	" 2SC2369			
		DIODE			
D1203,1205	G2090027	Silicon 1SS53			
D1201	G2015550	" 1S1555			
			***** 430 MHz BOOSTER BOARD *****		
			PB-1935B	F0001935B	Printed circuit board
				C9019350B	PCB with components
		RESISTOR			
R1215	J00245820	Carbon film 1/4W VJ 82Ω			
R1205,1210	J00245101	" " " " 100Ω			POWER MODULE
R1204	J00245221	" " " " 220Ω	Q1301	G1090217	UP-07BL
R1203(L1202), 1206(L1204), 1209(L1205), 1211(L1207), 1216-1218 (L1208-1210)	J10246471	Carbon composition " GK 470Ω			DIODE
R1212,1213	J00245102	Carbon film " VJ 1kΩ	D1301	G2090001	Silicon 10D1
R1201,1207,1223	J00245152	" " " " 1.5kΩ	D1302,1303	G2090118	Schottky barrier 1SS97

		RESISTOR	R1404,1410,1414	J00245101	Carbon film 1/4W VJ 1k Ω
R1306	J01245560	Carbon film 1/4W TJ 56 Ω	R1402,1411	J01245562	" " " TJ 5.6k Ω
R1302(L1309)	J10246471	Carbon composition 1/4W GK 470 Ω			
					CAPACITOR
			C1401-1410,1412	K22170001	Ceramic 0.001 μ F (HDC60E102M)
VR1301	J51729201	POTENTIOMETER RV8FAN 200 Ω B	C1411	K40120106	Electrolytic 16WV TW 10 μ F (16RL10)
					TRIMMER CAPACITOR
C1310	K02179001	CAPACITOR Ceramic disc 50WV CH 1pF (DD104CK010C50V02)	TC1401-1403, 1405,1406	K91000028	ECV-1ZW 10 x 53N 10pF
C1311	K02179003	" " " " 2pF (DD104CK020C50V02)			
C1304	K00172050	" " " " 5pF (DD104SL050C50V02)			INDUCTOR
C1308	K12171102	" " " " 0.001 μ F (DD105E102P50V02)	L1401-1406	L1020469	
	K40120106	Electrolytic 16WV TW 10 μ F (16RL10)	L1407	L0020472	
			L1409,1411	L0020473	
			L1408,1410,1412	L0020522	
				R5047914B	Heat sink L = 15 mm
				S5000015	" " NF-201AP
	K91000068	TRIMMER CAPACITOR ECV1ZW 06 x 32 6pF			
					INDUCTOR
L1308,1309	L1020469				
L1303,1304,1310	L0020770				
			***** 430 MHz CONVERTER BOARD *****		
			PB-1931	F0001931	Printed circuit board
				C9019310	PCB with components
		RELAY	PB-1932A	F0001932A	Printed circuit board
RL1301	M1590001	CX-140N (with J1301)		C9019320A	PCB with components
	Q4000003	Hermetic seal A350	PB-1933	F0001933	Printed circuit board
				C9019330	PCB with components
					TRANSISTOR
			Q1501,1502	G3314240	Transistor 2SC1424
			***** 430 MHz EXCITER BOARD *****		
PB-1930A	F0001930A	Printed circuit board			DIODE
	C9019300A	PCB with components	D1503-1506	G2090118	Schottky barrier 1SS97
			D1507-1510	G2090027	Silicon 1SS53
			D1501,1502,1512	G2090033	" MI-301
		TRANSISTOR	D1511	G2001880F	Germanium 1S188FM
Q1401	G3314240	Transistor 2SC1424			
Q1402,1403	G3314260	" 2SC1426			
					RESISTOR
			R1504	J00245180	Carbon film 1/4W VJ 18 Ω
		DIODE	R1517	J01245180	" " " TJ 18 Ω
D1401	G2015550	Silicon 1S1555	R1515	J00245220	" " " VJ 22 Ω
			R1510	J00245101	" " " " 100 Ω
			R1518,1519	J01245331	" " " TJ 330 Ω
		RESISTOR	R1502,1505	J00245331	" " " VJ 330 Ω
R1408	J00245330	Carbon film 1/4W VJ 33 Ω	R1511(L1507), 1512(L1510), 1516(L1511)	J10246471	Carbon composition
R1405	J00245820	" " " " 82 Ω			" GK 470 Ω
R1415	J00245221	" " " " 220 Ω			
R1401(L1401), 1406(L1402), 1407(L1403), 1412(L1404), 1413(L1405), 1416(L1406)	J10246471	Carbon composition " GK 470 Ω	R1513	J00245561	Carbon film " VJ 560 Ω
			R1501,1506	J01245102	" " " TJ 1k Ω
			R1503,1507	J00245102	" " " VJ 1k Ω
			R1508	J00245222	" " " " 2.2k Ω
			R1514	J01245103	" " " TJ 10k Ω
R1403,1409	J00245471	Carbon film " VJ 470 Ω	R1509	J01245223	" " " " 22k Ω

IMPORTANT NOTE

Your Yaesu equipment is backed by a warranty that guarantees your set to be free of defects. Take a few minutes to read the warranty card carefully. Make certain that you fill out the card completely, and mail it at once, in order to qualify for warranty service.

Warranty service is to be performed by the dealer from whom the equipment was purchased. Do not return the equipment to Yaesu for servicing without first getting a service authorization from the Yaesu Service Center. Estimates of the approximate cost to repair are available upon request.